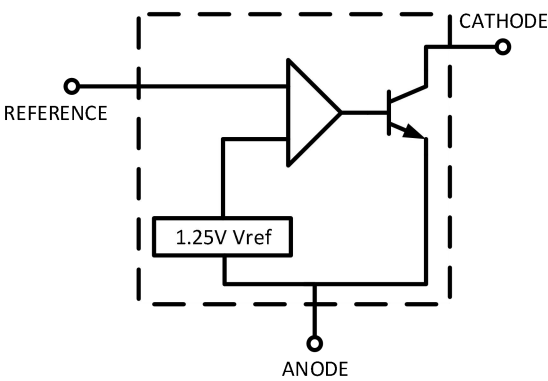

GT431VA/GT432VA Precision Programmable Reference

1 Features	2 Application
<ul style="list-style-type: none"> - Reference voltage tolerance 0.5% at 25°C - Programmable output voltage to 18V - Low dynamic output impedance 0.05Ω - Equivalent full-range temperature coefficient of 50ppm/°C maximum - Temperature compensated for operation over full rated operating temperature range - Low output noise voltage - Fast turn on response - Operation from -40°C to 125°C - Lead-Free packages: SOT23 	<ul style="list-style-type: none"> - Adjustable voltage and current referencing - Power supply - Zener replacement - Voltage monitoring - Comparator with integrated reference - As precision voltage reference

3 Description	Circuit Diagram
<p>The GT431VA and GT432VA device are three-terminal adjustable shunt regulators, with a guaranteed thermal stability over applicable temperature ranges. The output voltage can be set to any value between VREF (approximately 1.25V) and 18V with two external resistors. These devices provide a very sharp turn-on characteristic, making these devices excellent replacement for Zener diodes in many applications. Both the GT431VA and GT432VA devices are specified with an initial tolerance of 0.5% at 25°C.</p>	

4 Device Summary, Pin and Packages

Table. 4-1. Device Summary⁽¹⁾

Serial Name	Part Name	Package	Body Size (Nom)	Marking ⁽²⁾	MSL ⁽³⁾	Package Qty
GT431VA	GT431VAS3	SOT23(3)	2.90mm×1.30mm×1.10mm	GT431VA XXXX	3	Tape and Reel,3000
GT432VA	GT432VAS3	SOT23(3)	2.90mm×1.30mm×1.10mm	GT432VA XXXX	3	Tape and Reel,3000

(1) For all available packages, please contact product sales.

(2) There may be additional marking, which relates to the lot trace code information (data code and vendor code), the logo or the environmental category on the device.

(3) MSL, The Moisture Sensitivity Level rating according to the JEDEC industry standard classifications.

(4) "XXXXX" in Marking will be appeared as the batch code.

4 Device Summary, Pin and Packages(Continued)

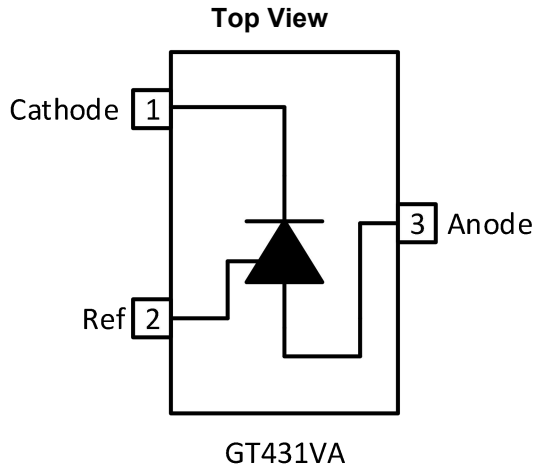

Fig.4-1. GT431VA: SOT23(3) Package

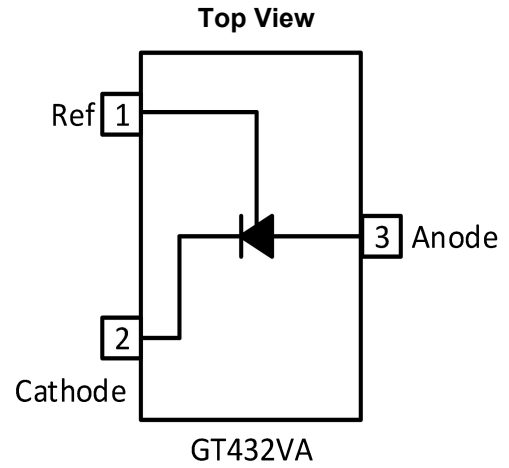

Fig.4-2. GT432VA: SOT23(3) Package

Table. 4-2. Pin Definition

Pin			I/O	Description
Name	GT431VA	GT432VA		
Cathode	1	2	I	Shunt Current/Voltage input
Ref	2	1	O	Threshold relative to common anode
Anode	3	3	-	Common pin, normally connected to ground

* It is suggested to leave the unconnected pins floating.

5 Voltage, Temperature, ESD and Thermal Ratings

5.1 Absolute Maximum Ratings^{(1) (2)}

Parameters	Symbol	Min.	Max.	Unit
Cathode Voltage	V_{KA}	-0.3	20	V
Cathode Current Range(Continuous)	I_{KA}	-100	+100	mA
Reference Input Current Range	I_{REF}	-0.05	+10	mA
Operating temperature	T_{opr}	-40	+125	°C
Power Dissipation	P_D	370		mW
Storage temperature	T_{stg}	-65	150	°C

(1) Stresses beyond those listed under Absolute Maximum Ratings may cause permanent damage to the device. These are stress ratings only, and functional operation of the device at these or any other conditions beyond those indicate under Recommended Operating Conditions is not implied. Exposure to absolute-maximum-rated conditions for extended periods may affect device reliability.

(2) All voltages are with respect to the GND pin.

5.2 ESD Ratings

ESD			Value	Unit
V(ESD)	Electrostatic discharge	Machine Model (MM)	400	V

5.3 Recommended Operating Conditions

Over operating free-air temperature range (unless otherwise noted)

Symbol	Parameters	Min.	Max.	Unit
VKA	Cathode Voltage	VREF	18	V
IKA	Cathode Current Range(Continuous)	0.15	100	mA
TA	Operating Ambient Temperature Range	-40	+125	°C

5.4 Thermal Information

THERMAL METRIC		GT431VA/GT432VA	Unit
$R_{\theta JA}$	Junction-to-ambient thermal resistance	185.6	°C/W
$R_{\theta JC(top)}$	Junction-to-case(top) thermal resistance	104.3	°C/W
$R_{\theta JB}$	Junction-to-board thermal resistance	54.5	°C/W
ψ_{JT}	Junction-to-top characterization parameter	31.0	°C/W
ψ_{JB}	Junction-to-board characterization parameter	54.5	°C/W
$R_{JC(bot)}$	Junction-to-case(bottom) thermal resistance	N/A	°C/W

6 Electrical Specifications

Over recommended operating conditions, FULL=-40°C to +125°C, Typical values are at TA=+25°C. (unless otherwise noted)

Parameters	Symbol	Conditions	Min.	Typ.	Max.	Unit	
Reference Input Voltage	V_{REF}	$V_{KA}=V_{REF}, I_{KA}=10mA$	0.5%	1.244	1.25	1.256	V
Deviation of reference Input Voltage Over temperature	ΔV_{REF}	$V_{KA}=V_{REF}, I_{KA}=10mA$ $T_{min} \leq T_A \leq T_{max}$	-	4	10	mV	
Ratio of Change in Reference Input Voltage to the Change In Cathode Voltage	$\Delta V_{REF} / \Delta V_{KA}$	$I_{KA}=10mA$ $\Delta V_{KA}=V_{REF} \sim 16V$	-	-0.5	-1.5	mV/V	
Reference Input Current	I_{REF}	$I_{KA}=10mA, R1=10k\Omega, R2=\infty$	-	0.15	0.4	μA	
Deviation of Reference Input Current Over Full Temperature Range	$\Delta I_{REF} / \Delta T_A$	$I_{KA}=10mA, R1=10k\Omega, R2=\infty$ $T_A = \text{full Temperature}$	-	0.1	0.4	μA	
Minimum cathode current for regulation	$I_{KA}(\text{min})$	$V_{KA}=V_{REF}$	-	55	80	μA	
Off-state cathode Current	$I_{KA}(\text{OFF})$	$V_{KA}=36V, V_{REF}=0V$	-	0.04	0.1	μA	
Dynamic Impedance	Z_{KA}	$V_{KA}=V_{REF}, I_{KA}=1 \text{ to } 100mA$ $f \leq 1.0KHz$	-	0.05	0.15	Ω	

7 Detailed Description

7.1 Overview

This standard component has been widely adopted in various applications, from power supplies to signal paths. It integrates crucial elements, such as a precision voltage reference and an operational amplifier, which are essential analog building blocks. When combined with its key components, the GT431VA/GT432VA family can be set up as a standalone voltage reference, error amplifier, voltage clamp, or comparator with an integrated reference.

7.2 Feature Description

The GT431VA/GT432VA can operate with cathode voltages adjustable within a range of 1.25V to 18V. It is optimized for end-equipment applications in industrial, automotive, telecommunications, and computing systems. When used as a shunt regulator or error amplifier, a minimum cathode current greater than 80 μA ($I_{\text{min(max)}}$) must be ensured. In these configurations, the feedback between the cathode and reference pins allows the replication of the internal reference voltage. The operating temperature range of the GT431VA device is from -40°C to 125°C .

8 Application Note

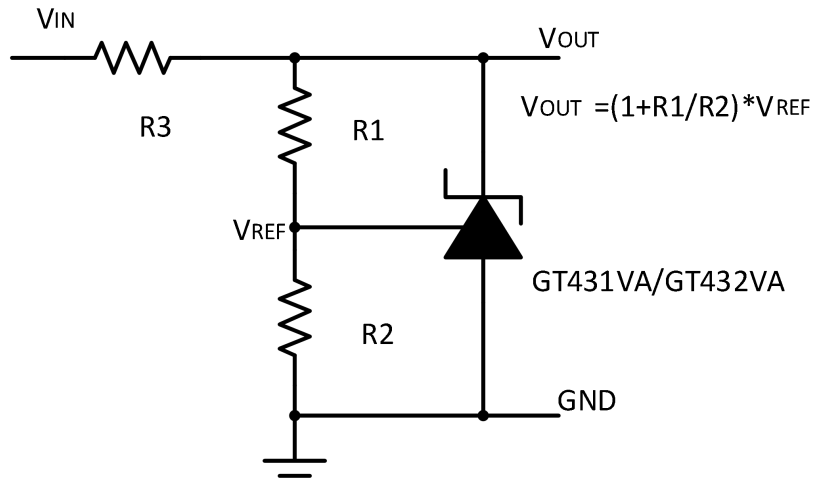

Fig.8-1. Shunt Regulator

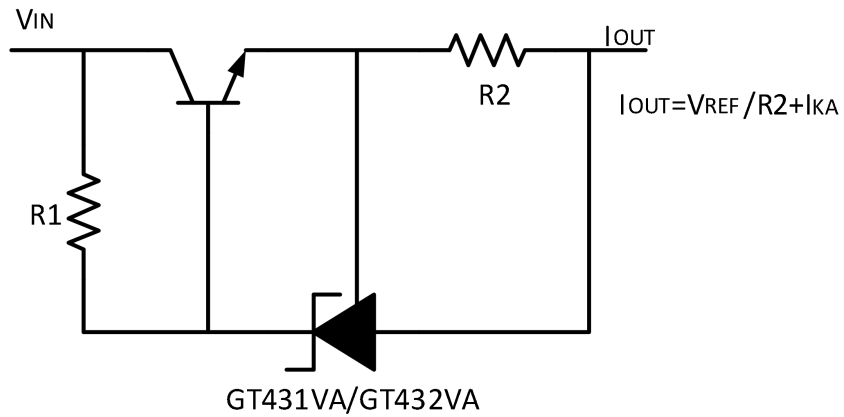

Fig.8-2. Current Source or Current Limit

8 Application Note(Continued)

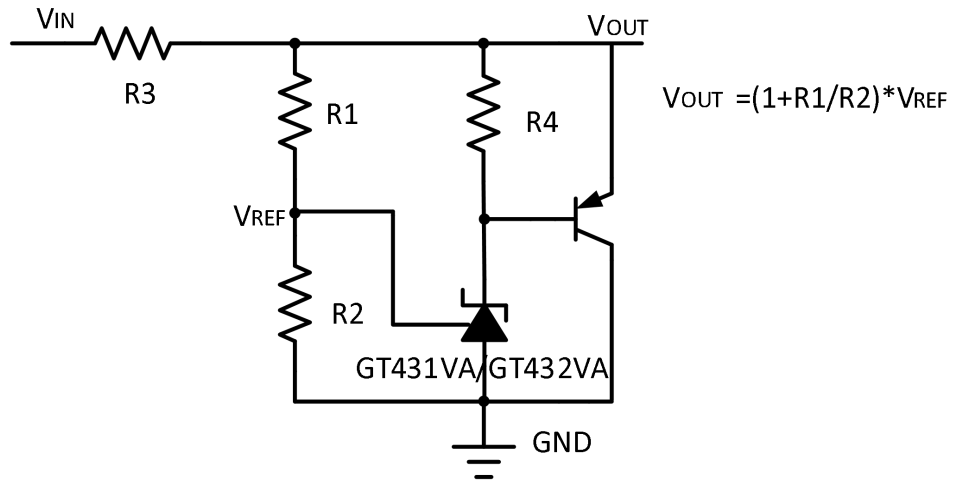

Fig.8-3. High Current Shunt Regulator

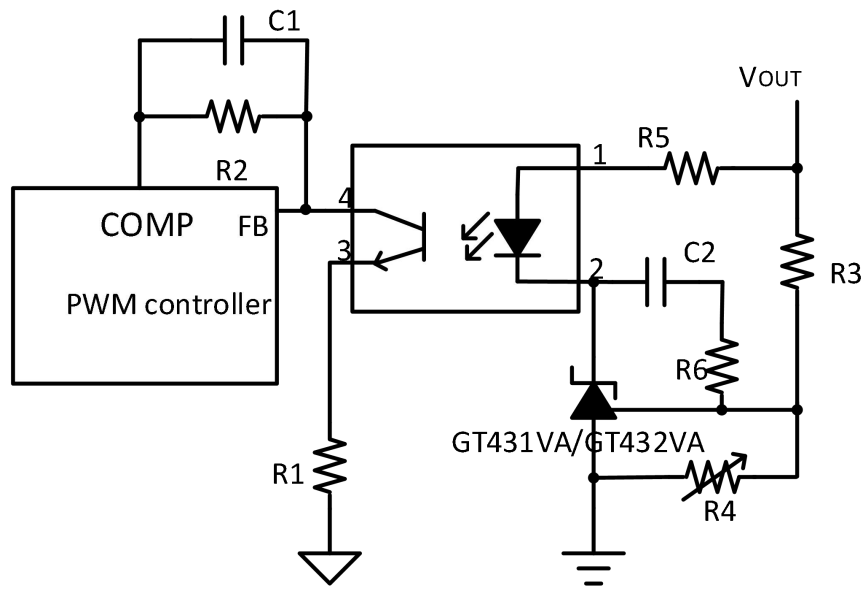
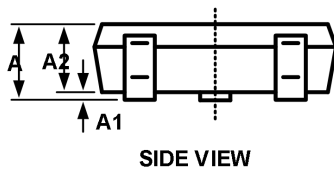
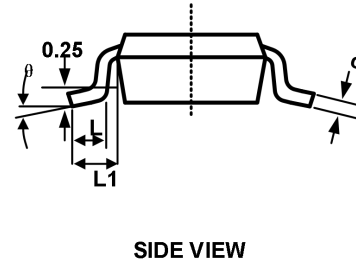
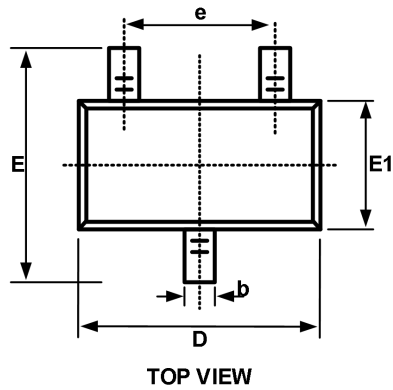

Fig.8-4. PWM Converter with Reference

9 Package Outline Dimension

SOT23-3



Recommended Land Pattern (Unit: mm)

Symbol	Dimensions in Millimeters		Dimensions in Inches	
	Min.	Max.	Min.	Max.
A	1.050	1.250	0.041	0.049
A1	0.000	0.100	0.000	0.004
A2	0.900	1.100	0.035	0.043
b	0.300	0.500	0.012	0.020
c	0.132	0.202	0.005	0.008
D	2.800	3.000	0.110	0.118
E	2.250	2.550	0.089	0.100
E1	1.200	1.400	0.047	0.055
e	1.800	2.000	0.071	0.079
L	0.300	0.500	0.012	0.020
L1	0.550 REF		0.022 REF	
θ	0°	8°	0°	8°

10 Tape and Reel Information

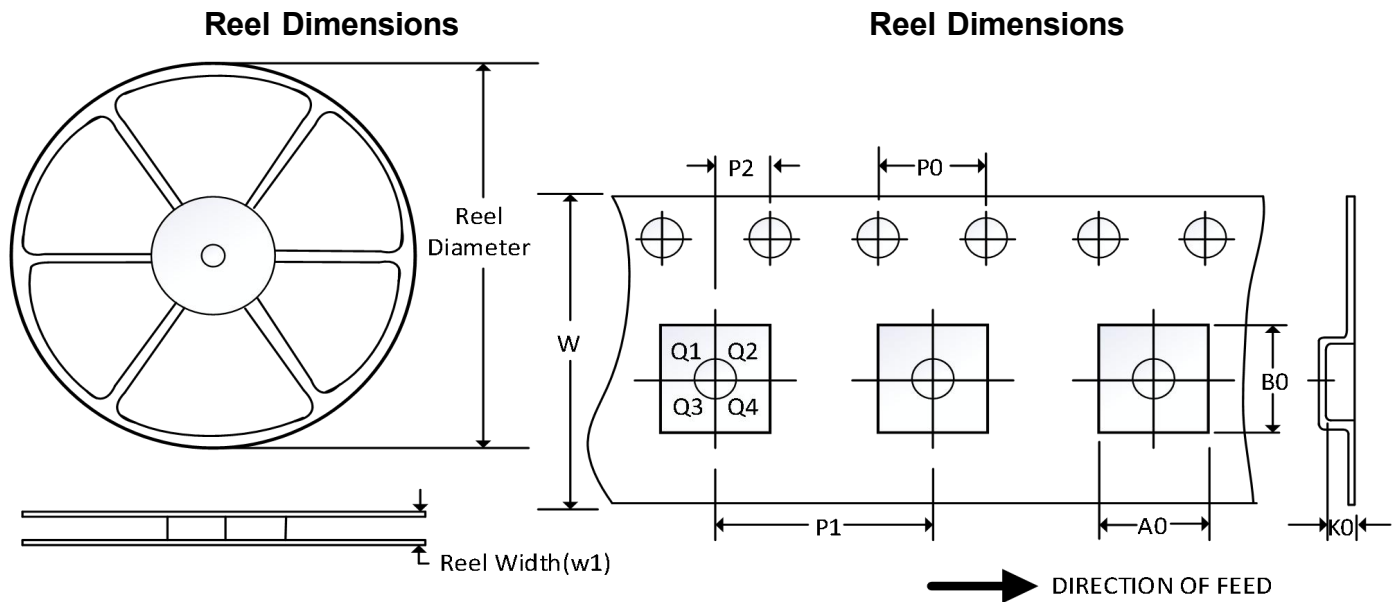

NOTE: The picture is only for reference. Please make the object as the standard.

Key Parameter List of Tape and Reel

Package Type	Reel Diameter	Reel Width (mm)	A0 (mm)	B0 (mm)	K0 (mm)	P0 (mm)	P1 (mm)	P2 (mm)	W (mm)	Pin1 Quadrant
SOT23-3	7"	9.5	3.20	3.20	1.40	4.0	4.0	2.0	8.0	Q3

NOTE:

1. All dimensions are nominal.
2. Plastic or metal protrusions of 0.15mm maximum per side are not included.