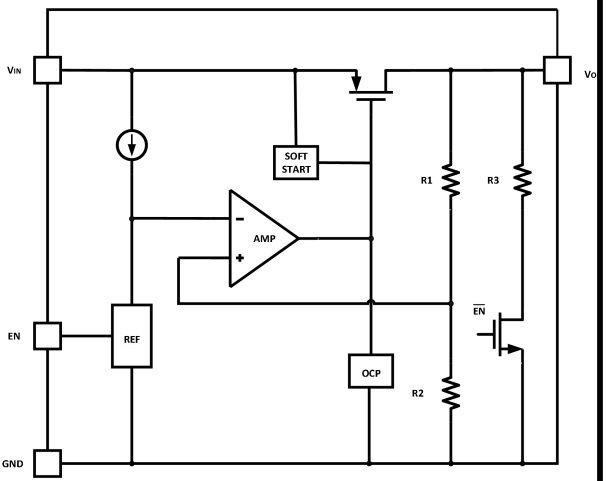

## GT2136

### High-PSRR, Low-Dropout, 400mA Linear Regulator

1 Features	2 Application
<ul style="list-style-type: none"> <li>- Maximum output current 400mA</li> <li>- Low voltage drop 75mV@50mA, VOUT =3.3V</li> <li>- Low temperature coefficient</li> <li>- Withstanding voltage 10V</li> <li>- Quiescent current 2.0μA@6V</li> <li>- Output voltage accuracy: 2%</li> <li>- Output short circuit protection</li> <li>- Output current limit</li> <li>- High PSRR 76dB @ 1kHz</li> <li>- Low output noise: 70μVRMS @10~100KHz</li> </ul>	<ul style="list-style-type: none"> <li>- Temperature sensors</li> <li>- Battery-powered equipments</li> <li>- Communication equipments</li> <li>- Audio/Video equipments</li> <li>- Smart battery packs</li> <li>- Smoke detectors</li> <li>- EV and HEV battery management systems</li> </ul>

3 Description	Circuit Diagram
<p>The GT2136 series is a three-terminal step-down regulator with high precision, low voltage drop, and low quiescent current. The input voltage range is 10V. It offers large current output capability under extremely small voltage difference conditions and features a good regulation rate. The GT2136 delivers up to 400mA of output current as a high-PSRR linear regulator. The enable pin EN controls the chip to enter standby mode, significantly reducing quiescent current consumption.</p>	

## 4 Device Summary, Pin and Packages

**Table 4-1. Device Summary<sup>(1)</sup>**

Serial Name	Part Name	VOUT(V)	Package	VOUT Accuracy	Marking <sup>(2)</sup>	MSL <sup>(3)</sup>	Package Qty
GT2136	GT2136-1.5S5	1.5	SOT23-5	±2%	AKH XXXXX	3	Tape and Reel,3000
	GT2136-1.5S3	1.5	SOT23-3	±2%	AKG XXXX	3	Tape and Reel,3000
	GT2136-1.5DA4	1.5	DFN1*1-4L	±2%	AKC XXXX	3	Tape and Reel,10000
GT2136	GT2136-1.8S5	1.8	SOT23-5	±2%	ALH XXXXX	3	Tape and Reel,3000
	GT2136-1.8S3	1.8	SOT23-3	±2%	ALG XXXX	3	Tape and Reel,3000
	GT2136-1.8DA4	1.8	DFN1*1-4L	±2%	ALC XXXX	3	Tape and Reel,10000
GT2136	GT2136-2.5S5	2.5	SOT23-5	±2%	AQH XXXXX	3	Tape and Reel,3000
	GT2136-2.5S3	2.5	SOT23-3	±2%	AQG XXXX	3	Tape and Reel,3000
	GT2136-2.5DA4	2.5	DFN1*1-4L	±2%	AQC XXXX	3	Tape and Reel,10000
GT2136	GT2136-2.8S5	2.8	SOT23-5	±2%	ATH XXXXX	3	Tape and Reel,3000
	GT2136-2.8S3	2.8	SOT23-3	±2%	ATG XXXX	3	Tape and Reel,3000
	GT2136-2.8DA4	2.8	DFN1*1-4L	±2%	ATC XXXX	3	Tape and Reel,10000
GT2136	GT2136-3.0S5	3.0	SOT23-5	±2%	AWH XXXXX	3	Tape and Reel,3000
	GT2136-3.0S3	3.0	SOT23-3	±2%	AWG XXXX	3	Tape and Reel,3000
	GT2136-3.0DA4	3.0	DFN1*1-4L	±2%	AWC XXXX	3	Tape and Reel,10000
GT2136	GT2136-3.3S5	3.3	SOT23-5	±2%	AXH XXXXX	3	Tape and Reel,3000
	GT2136-3.3S3	3.3	SOT23-3	±2%	AXG XXXX	3	Tape and Reel,3000
	GT2136-3.3DA4	3.3	DFN1*1-4L	±2%	AXC XXXX	3	Tape and Reel,10000
GT2136	GT2136-5.0S5	5.0	SOT23-5	±2%	A2H XXXXX	3	Tape and Reel,3000
	GT2136-5.0S3	5.0	SOT23-3	±2%	A2G XXXX	3	Tape and Reel,3000
	GT2136-5.0DA4	5.0	DFN1*1-4L	±2%	A2C XXXX	3	Tape and Reel,10000

(1) For all available packages, please contact product.

(2) There may be additional marking, which relates to the lot trace code information (data code and vendor code), the logo or the environmental category on the device.

(3) MSL, The Moisture Sensitivity Level rating according to the JEDEC industry standard classifications.

(4) "XXXXX" in Marking will be appeared as the batch code.

### 4 Device Summary, Pin and Packages(Continued)

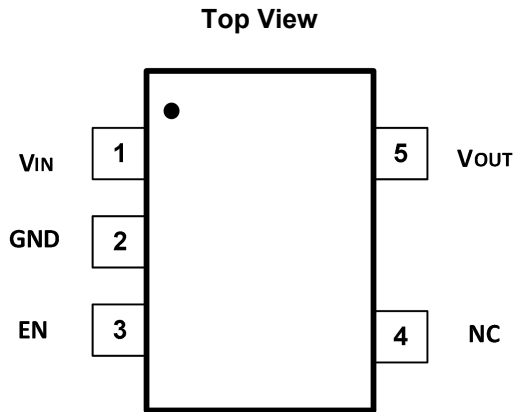

Fig.4-1. GT2136: S5(SOT23-5) Package

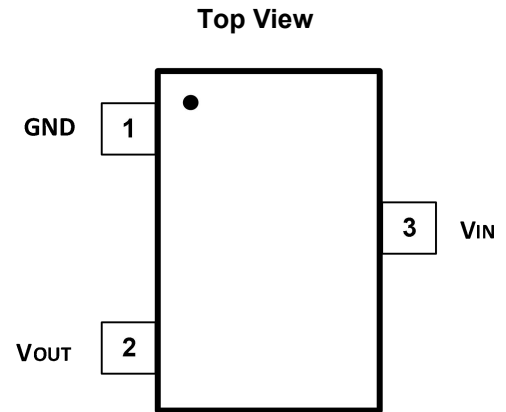

Fig.4-2. GT2136: S3(SOT23-3) Package

Table 4-2 Pin Definition

Name	Pin		I/O	Description
	S5	S3		
VIN	1	3	I	Input
GND	2	1	-	GND
EN	3	-	I	Enable channel
NC	4	-	-	No connection
VOUT	5	2	O	Output

\* It is suggested to leave the unconnected pins floating

**4 Device Summary, Pin and Packages(Continued)**

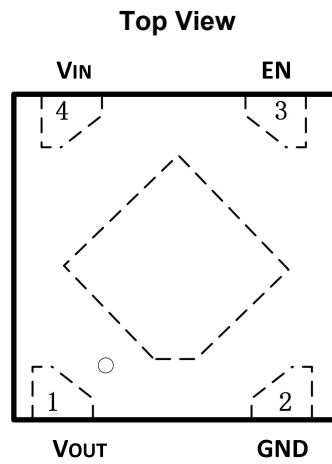

**Fig.4-3. GT2136: DFN (DFN1\*1-4L) Package**

**Table 4-3 Pin Definition**

Name	Pin DFN	I/O	Description
VIN	4	I	Input
VOUT	1	O	Output
GND	2	-	GND
EN	3	I	Enable channel

\* It is suggested to leave the unconnected pins floating.

## 5 Voltage, Temperature, ESD and Thermal Ratings

### 5.1 Absolute Maximum Ratings<sup>(1)</sup>

Parameters	Min	Max	Unit
Supply input voltage	-0.3	12.0	V
Operating free air temperature rang	-40	85	°C
Maximum junction temperature	-	150	°C
Storage temperature range	-55	150	°C

(1) Stresses above these ratings may cause permanent damage. Exposure to absolute maximum conditions for extended periods may degrade device reliability. These are stress ratings only, and functional operation of the device at these or any other conditions beyond those specified is not implied.

### 5.2 ESD Ratings

ESD			Value	Unit
V(ESD)	Electrostatic Discharge	Human-Body Model (HBM) <sup>(1)</sup>	2.5K	V

(1) JEDEC document JEP155 states that 500-V HBM allows safe manufacturing with a standard ESD control process.

### 5.3 Recommended Operating Conditions<sup>(1)</sup>

Over operating free-air temperature range (unless otherwise noted)

Symbol	Parameter	Min	Max	Units
T <sub>A</sub>	Operating Temperature	-40	85	°C

### 5.4 Thermal Information

Package Type	θ <sub>JA</sub>	θ <sub>JC</sub>	Unit
SOT23-3	185	104	°C/W
SOT23-5	250	81	°C/W
DFN1*1-4L	120	60	°C/W

## 6 Electrical Specifications

Typical values are at TA=+25°C, CIN=COUT=1μF. (unless otherwise noted)

Parameter	Symbol	Condition	Min	Typ	Max	Unit
Input voltage	V <sub>IN</sub>		2.2		10	V
Quiescent current	I <sub>SS</sub>	V <sub>IN</sub> =6V, I <sub>OUT</sub> =0mA		2.0	3	μA
	I <sub>SS</sub>	V <sub>IN</sub> =10V, I <sub>OUT</sub> =0mA		2.5	6	μA
Standby current	I <sub>STB</sub>	V <sub>EN</sub> =0V			0.1	μA
Voltage accuracy	V <sub>OUT</sub>	V <sub>IN</sub> = V <sub>OUT</sub> +1V, I <sub>OUT</sub> =1mA	-2		+2	%
Line regulation	$\Delta V_{OUT}/(\Delta V_{IN} \cdot V_{OUT})$	V <sub>OUT</sub> +1V ≤ V <sub>IN</sub> ≤ 6V, I <sub>OUT</sub> =10mA		0.02	0.1	%/V
Load regulation	$\Delta V_{OUT}$	V <sub>IN</sub> = V <sub>OUT</sub> +1V, 1mA ≤ I <sub>OUT</sub> ≤ 200mA		0.2	1	%
Temperature coefficient	$\Delta V_{OUT}/(\Delta T \cdot V_{OUT})$	I <sub>OUT</sub> =10mA, -25°C ≤ T ≤ 85°C		±100		ppm/°C
Output current	I <sub>OUT</sub>	V <sub>IN</sub> = V <sub>OUT</sub> +1V		400		mA
Voltage drop	V <sub>DROP</sub>	I <sub>O</sub> =50mA, V <sub>OUT</sub> ≤ 2.0V		160		mV
	V <sub>DROP</sub>	I <sub>O</sub> =50mA, 2.0V < V <sub>OUT</sub> ≤ 3.0V		120		mV
	V <sub>DROP</sub>	I <sub>O</sub> =50mA, 3.0V < V <sub>OUT</sub> ≤ 5.0V		75		mV
Ripple rejection rate	PSRR	V <sub>IN</sub> =5V+1 V <sub>P-P</sub> (AC), f=1KHZ, V <sub>OUT</sub> =3.3V, I <sub>OUT</sub> =50mA		76		dB
Output noise	EN	BW=10Hz~100KHz		70		μVrms
EN high voltage	V <sub>IH</sub>	V <sub>IN</sub> =5V	1.2			V
EN low voltage	V <sub>IL</sub>	V <sub>IN</sub> =5V			0.4	V
Discharge resistor	R <sub>D</sub>			500		Ω

## 7 Typical Characteristics

Typical values are at TA=+25°C, C<sub>IN</sub>=C<sub>OUT</sub>=1μF. (unless otherwise noted)

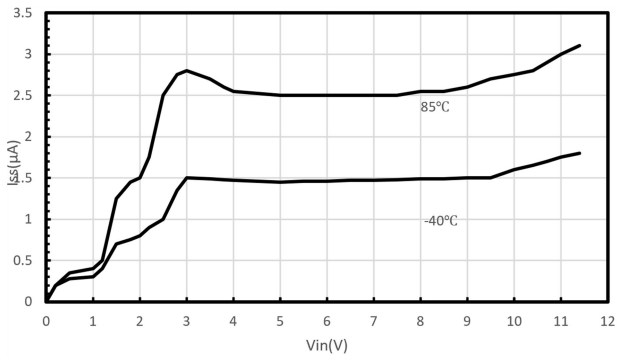

**Fig.7-1. I<sub>SS</sub> VS V<sub>IN</sub>**

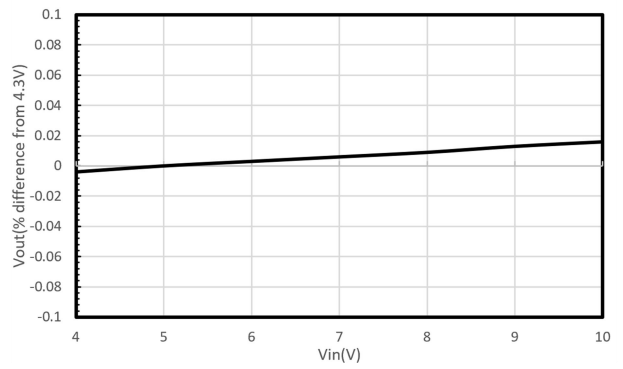

**Fig.7-2. V<sub>OUT</sub> VS V<sub>IN</sub>**

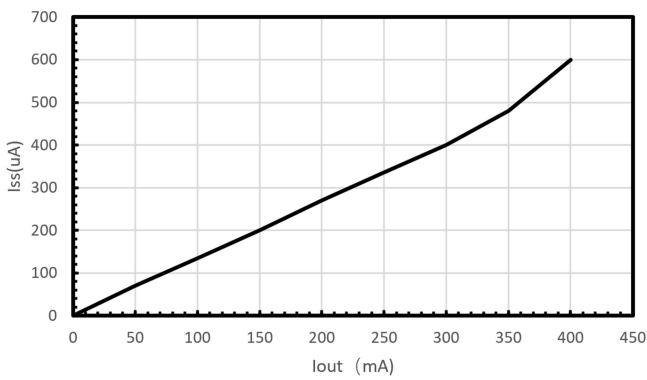

**Fig.7-3. I<sub>SS</sub> VS V<sub>OUT</sub>**

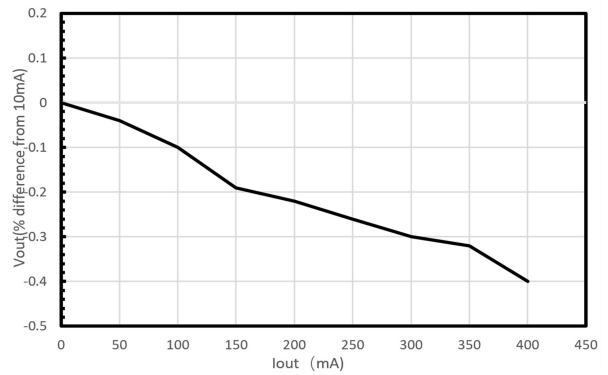

**Fig.7-4. V<sub>OUT</sub> VS I<sub>OUT</sub>**

## **8 Detailed Description**

### **8.1 Overview**

The GT2136 series is a three-terminal step-down regulator with high precision, low voltage drop and low quiescent. The input voltage range 10V. It can provide large current output capability under extremely under extremely small voltage difference conditions and has good regulation rate. It can provide large current output under small voltage difference and has good regulation rate. The GT2136 is deliver up to 400mA of output current, high-PSRR linear regulator.

### **8.2 Feature Description**

The enable pin EN can control the chip to enter standby mode, which greatly reduces the static current consumption. It is particularly suitable for applications with strict requirements on battery life. The device is protected from short circuit events by the current limit function and from overheating by means of thermal shutdown protection widely used in audio video and communication appliances.

## 9 Application Note

### 9.1 Output Capacitor

An output capacitor is required for the stability of the LDO. The recommend output capacitance is  $1.0\mu\text{F}$ . A ceramic capacitor is recommended with the temperature characteristics of X7R or X5R. Higher capacitance help to improve load/line transient response. The output capacitance may be increased to keep low undershoot/overshoot. Place output capacitor as close as possible to OUT and GND pins

### 9.2 Input Capacitor

A  $1\mu\text{F}$  ceramic capacitor is recommended to connect between VIN and GND pins to decouple input power supply glitch and noise. The amount of the capacitance may be increased without limit. This input capacitor must close as possible to the device to assure input stability and less noise. For PCB layout, a wide copper trace is required for both VIN and GND.

### 9.3 Current-Limit and Short-Circuit Protection

When the output current at VOUT pin is higher than the current-limit three the VOUT pin is directly shorted to GND, current-limit protection will trigger and clamp the output current at a pre-designed level to prevent and thermal damage

### 9.4 Layout Considerations

For good ground loop and stability, the input and output capacitors should the input, output, and ground pins of the device. The regulator ground pin should be connected to the external circuit ground to age drop caused by trace impedance. Ground plane is generally used to reduce trace impedance. Wide trace should be used for large paths from VIN to VOUT, and load circuit

### 9.5 Power Estimation

In order to make the chip work within the limit range and maintain a stable output voltage, the power consumption PD of the chip must not exceed the maximum power consumption PD(MAX), that is,  $PD < PD(\text{MAX})$ . Ass can be seen from the figure below, almost all power is generated by the transmission transistor, which is equivalent to connecting a variable resistor with the load to keep the output voltage constant. It will generate power consumption in the form of heat energy, and it must be ensured that the chip does not exceed the maximum junction temperature.

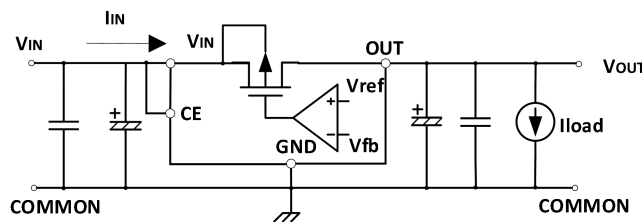

**Fig.9-1. Equivalent Input Circuit**

# 10 Package Outline Dimension

SOT23-5

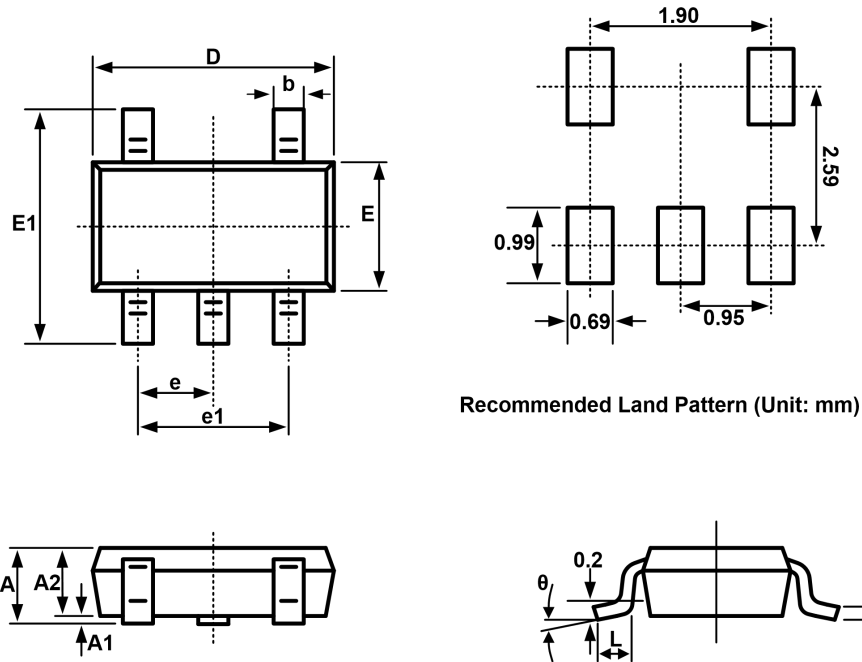

Symbol	Dimensions in Millimeters		Dimensions in Inches	
	Min.	Max.	Min.	Max.
A	1.050	1.250	0.041	0.049
A1	0.000	0.100	0.000	0.004
A2	1.050	1.150	0.041	0.045
b	0.300	0.500	0.012	0.020
c	0.100	0.200	0.004	0.008
D	2.820	3.020	0.111	0.119
E	1.500	1.700	0.059	0.067
E1	2.650	2.950	0.104	0.116
e	0.950(BSC)		0.037(BSC)	
e1	1.800	2.000	0.071	0.079
L	0.300	0.600	0.012	0.024
θ	0°	8°	0°	8°

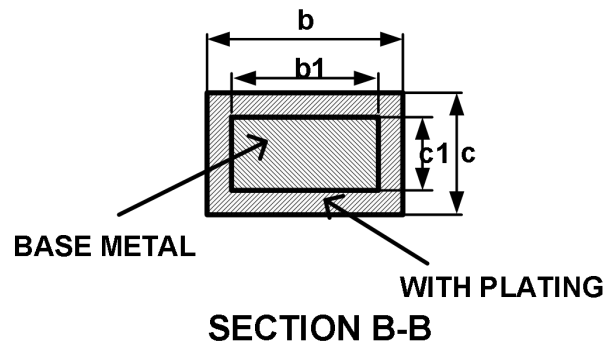
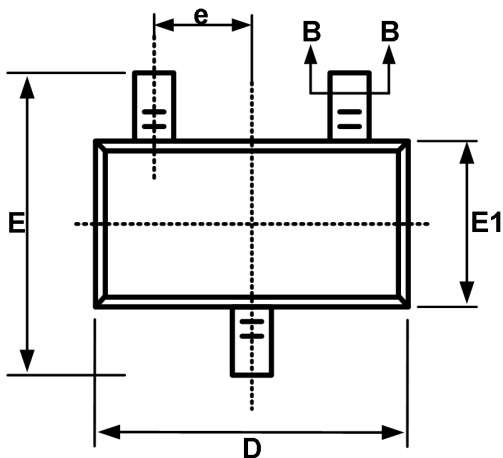
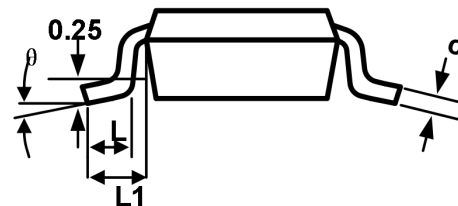
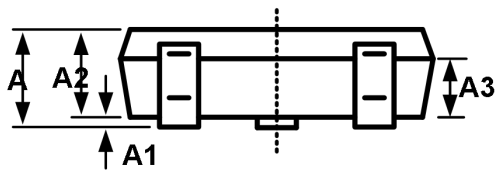
**10 Package Outline Dimension(Continued)**
**SOT23-3**

**Recommended Land Pattern (Unit: mm)**

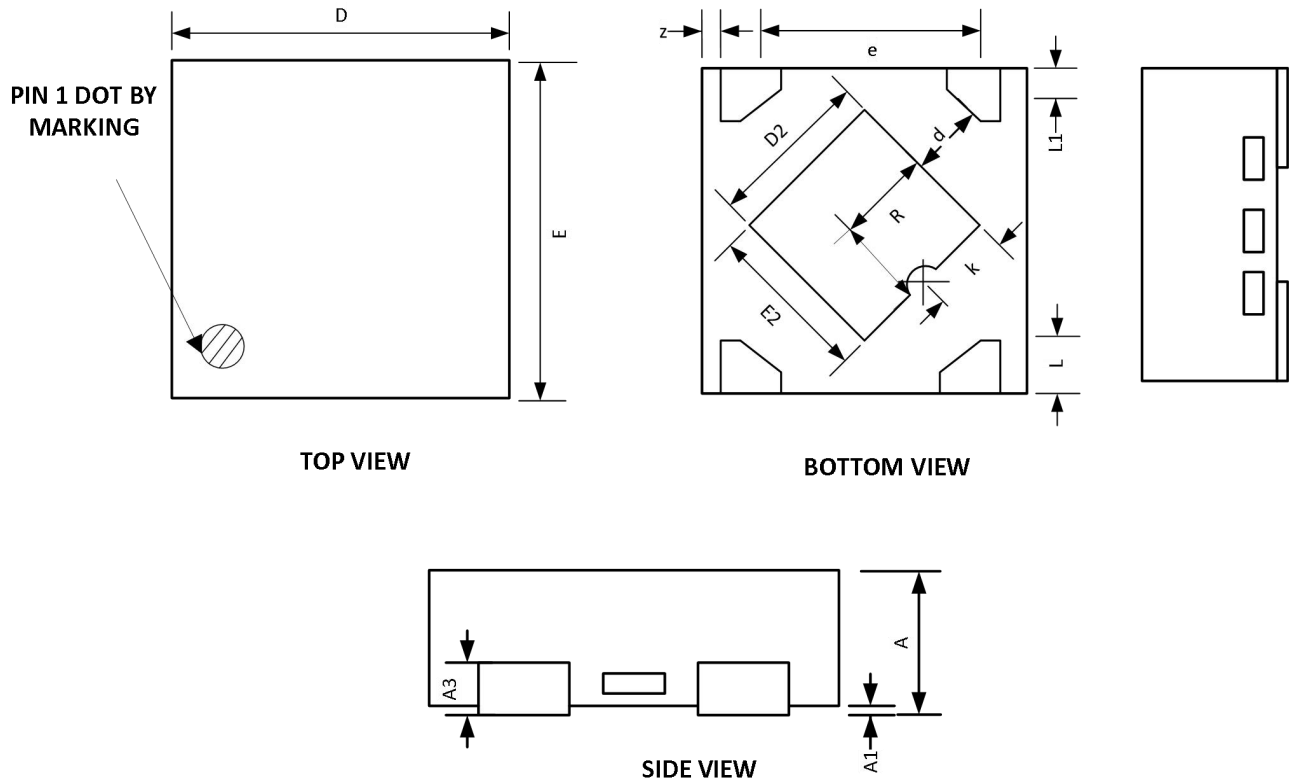
Symbol	Dimensions in Millimeters		Dimensions in Inches	
	Min.	Max.	Min.	Max.
A	1.05	1.25	0.041	0.049
A1	0.04	0.10	0.001	0.004
A2	1.00	1.20	0.039	0.047
A3	0.60	0.70	0.024	0.028
b	0.33	0.41	0.013	0.016
b1	0.32	0.38	0.013	0.015
c	0.15	0.19	0.006	0.007
c1	0.14	0.16	0.006	0.006
D	2.82	3.02	0.111	0.119
E	2.60	3.00	0.102	0.118
E1	1.50	1.70	0.059	0.067
e	0.95BSC		0.037BSC	
L	0.30	0.60	0.012	0.024
L1	0.60REF		0.024REF	
θ	0°	8°	0°	8°

**10 Package Outline Dimension(Continued)**
**DFN1\*1-4L**

Symbol	Dimensions in Millimeters			Dimensions in Inches		
	Min.	Nom.	Max.	Min.	Nom.	Max.
A	0.35	0.38	0.40	0.14	0.15	0.16
A1	0.00	0.03	0.05	0.00	0.01	0.02
A3	0.127REF			0.127REF		
D	0.95	1.00	1.05	0.37	0.39	0.41
E	0.95	1.00	1.05	0.37	0.39	0.41
b	0.27	0.25	0.30	0.11	0.10	0.12
L	0.20	0.25	0.30	0.08	0.10	0.12
D2	0.43	0.48	0.53	0.17	0.19	0.21
E2	0.43	0.48	0.53	0.17	0.19	0.21
e	0.65 BSC			0.65 BSC		
k	0.19	0.24	0.29	0.07	0.09	0.11
L1	0.02	0.07	0.12	0.01	0.03	0.05
R	0.02	0.05	0.08	0.01	0.02	0.03
z	0.05REF			0.05REF		
d	0.205REF			0.205REF		

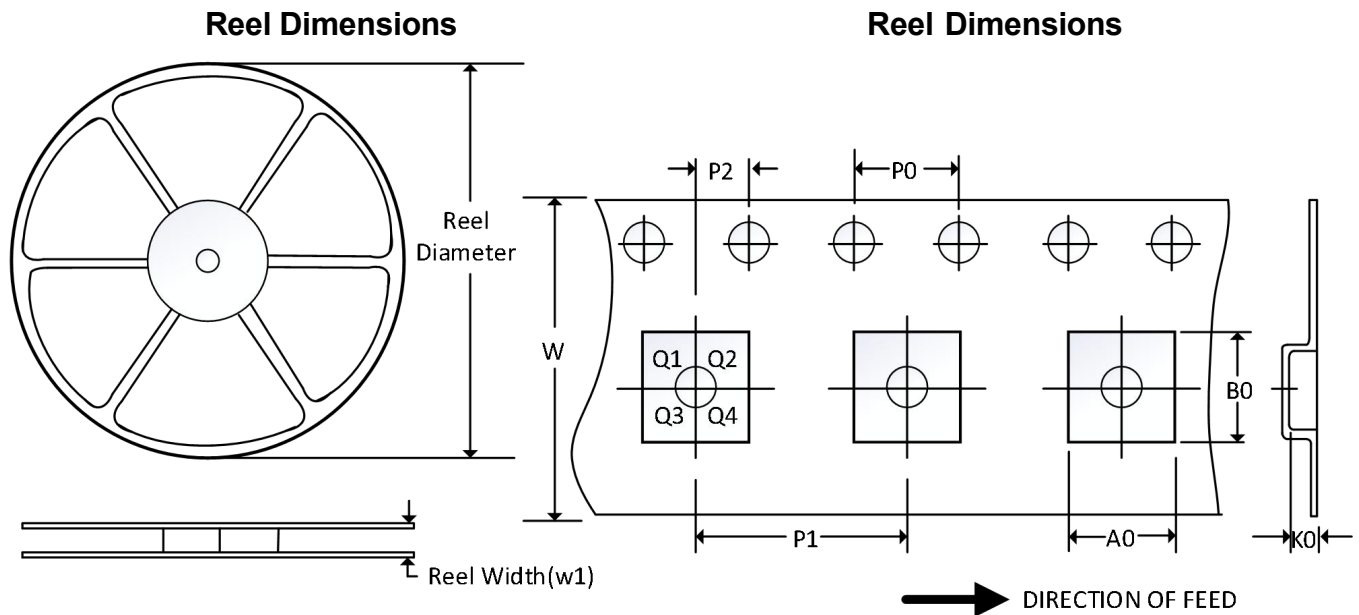
## 11 Tape and Reel Information



NOTE: The picture is only for reference. Please make the object as the standard.

### Key Parameter List of Tape and Reel

Package Type	Reel Diameter	Reel Width(m m)	A0 (mm)	B0 (mm)	K0 (mm)	P0 (mm)	P1 (mm)	P2 (mm)	W (mm)	Pin1 Quadrant
SOT23-5	7"	9.5	3.20	3.20	1.40	4.0	4.0	2.0	8.0	Q3
SOT23-3	7"	9.5	3.20	3.20	1.40	4.0	4.0	2.0	8.0	Q3
DFN1 *1-4L	7"	9.0	1.15	1.15	0.55	4	2	2	8	Q1

NOTE:

1. All dimensions are nominal.
2. Plastic or metal protrusions of 0.15mm maximum per side are not included.