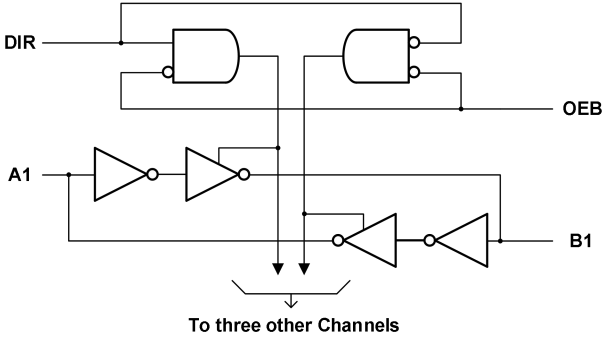


## GT74LVC4T245

### 4-bit Dual-Supply Bus Transceiver with Voltage Translation

1 Features	2 Application
<ul style="list-style-type: none"> <li>- Control inputs <math>V_{IH}/V_{IL}</math> levels are referenced to <math>V_{CCA}</math></li> <li>- <math>V_{CC}</math> isolation feature – if either <math>V_{CC}</math> input is at GND, all are in the high-impedance state</li> <li>- Fully configurable dual-rail design allows each port to operate over the full 1.65V to 5.5V power supply range</li> <li>- Recommended temperature range: <math>-40^{\circ}\text{C}</math> to <math>+125^{\circ}\text{C}</math></li> </ul>	<ul style="list-style-type: none"> <li>- Personal electronic</li> <li>- Industrial</li> <li>- Enterprise</li> <li>- Telecom</li> </ul>

3 Description	Circuit Diagram
<p>This 4-bit noninverting bus transceiver uses two separate power-supply rails. The GT74LVC4T245 is optimized to operate with <math>V_{CCA}</math> and <math>V_{CCB}</math> set at 1.65V to 5.5V. The A port is designed to track <math>V_{CCA}</math>. <math>V_{CCA}</math> accepts any supply voltage from 1.65V to 5.5V. The B port is designed to track <math>V_{CCB}</math>. <math>V_{CCB}</math> accepts any supply voltage from 1.65V to 5.5V. This allows for universal low-voltage bidirectional translation between any of the 1.8V, 2.5V, 3.3V, and 5.5V voltage nodes. The logic levels of the direction-control (DIR) input and the output-enable (OEB) input activate either the B-port outputs or the A-port outputs or place both output ports into the high-impedance mode. The device transmits data from the A bus to the B bus when the B-port outputs are activated, and from the B bus to the A bus when the A-port outputs are activated. The input circuitry on both A and B ports is always active and have a logic HIGH or LOW level applied to prevent excess <math>I_{CC}</math> and <math>I_{CCZ}</math>. The GT74LVC4T245 is designed so that the control pins are supplied by <math>V_{CCA}</math>.</p>	 <p>The circuit diagram shows the internal logic of the transceiver. It features a direction-control input (DIR) and an output-enable input (OEB). The DIR input is connected to two 2-input AND gates. The OEB input is connected to two 2-input AND gates. The A1 input is connected to a 2-input AND gate. The B1 input is connected to a 2-input AND gate. The outputs of these AND gates are connected to the input and output drivers of the A and B ports. A note indicates that the device is connected to three other channels.</p>

## 4 Revision History

Revision	Date	Note
Rev. A1. 0	2023. 10. 21	Original Version
Rev. A1. 1	2023. 10. 24	1.Updated Package Qty 2.Added Tape and Reel Information 3.Added Application Note
Rev. A1. 2	2023. 12. 26	1. Added Marking 2.Added MSL
Rev. A1. 3	2024. 01. 26	Updated Part Name

The latest datasheet version should be checked on the GTIC official website, as the company does not actively inform customers about updates to the datasheet.

## 5 Device Summary, Pin and Packages

Table.5-1. Device Summary<sup>(1)</sup>

Serial Name	Part Name	Package	Body Size (Nom)	Marking <sup>(2)</sup>	MSL <sup>(3)</sup>	Package Qty
GT74LVC4T245	GT74LVC4T245TE	TSSOP16	4.98mmx4.40mmx1.20mm	GT74LVC4T245 XXXXXXX	3	Tape and Reel,4000

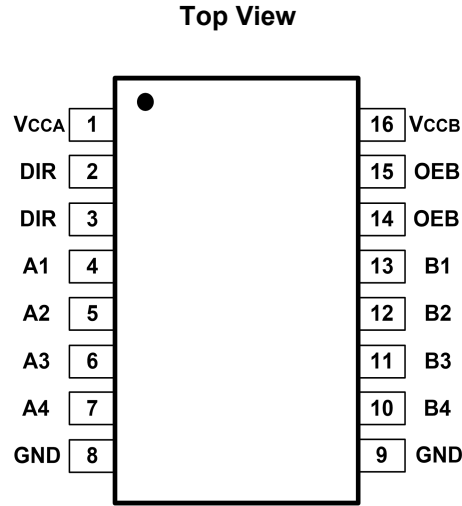
(1)For all available packages, please contact product sales.

(2)There may be additional marking, which relates to the lot trace code information (data code and Vendor code), the logo or the environmental category on the device.

(3)MSL, The Moisture Sensitivity Level rating according to the JEDEC industry standard classifications.

(4)"XXXXX" in Marking will be appeared as the batch code.

## 5 Device Summary, Pin and Packages(Continued)



**Fig.5-1. GT74LVC4T245: TE (TSSOP16) Package**

**Table.5-2. Pin Definition**

PIN		I/O	Description
Name	TE		
A1	4	I/O	Input/output A1. Referenced to VCCA.
A2	5	I/O	Input/output A2. Referenced to VCCA.
A3	6	I/O	Input/output A3. Referenced to VCCA.
A4	7	I/O	Input/output A4. Referenced to VCCA.
B1	13	I/O	Input/output B1. Referenced to VCCB.
B2	12	I/O	Input/output B2. Referenced to VCCB.
B3	11	I/O	Input/output B3. Referenced to VCCB.
B4	10	I/O	Input/output B4. Referenced to VCCB.
OEB	14,15	I	3-state output-mode enables. Pull OEB high to place all outputs in 3-state mode. Referenced to VCCA.
DIR	2,3	I	Direction-control signal.
V <sub>CCA</sub>	1	-	A-port supply voltage. $1.65V \leq V_{CCA} \leq 5.5 V$
V <sub>CCB</sub>	16	-	B-port supply voltage. $1.65V \leq V_{CCB} \leq 5.5 V$
GND	8,9	-	Ground.

\* All unused input pins cannot be suspended and suggested to connect to GND.

## 6 Voltage, Temperature, ESD and Thermal Ratings

### 6.1 Absolute Maximum Ratings<sup>(1)</sup>

Parameters			Min	Max	Unit
Supply voltage range, VCCA, VCCB			-0.5	6.5	V
VI	Input voltage range <sup>(2)</sup>	I/O ports (A port)	-0.5	6.5	V
		I/O ports (B port)	-0.5	6.5	
		Control inputs	-0.5	6.5	
VO	Voltage range applied to any output in the high-impedance or power-off state <sup>(2)</sup>	A port	-0.5	6.5	V
		B port	-0.5	6.5	
VO	Voltage range applied to any output in the high or low state <sup>(2)</sup> <sup>(3)</sup>	A port	-0.5	VCCA + 0.5	V
		B port	-0.5	VCCB + 0.5	
IIK	Input clamp current	VI < 0		-50	mA
IOK	Output clamp current	VO < 0		-50	mA
IO	Continuous output current			±50	mA
Continuous current through each VCCA, VCCB, and GND				±100	mA

(1)Stresses beyond those listed under "absolute maximum ratings" may cause permanent damage to the device. These are stress ratings only, and functional operation of the device at these or any other conditions beyond those indicated under "recommended operating conditions" is not implied. Exposure to absolute-maximum-rated conditions for extended periods may affect device reliability.

(2)The input and output negative-voltage ratings may be exceeded if the input and output current ratings are observed.

(3)The output positive-voltage rating may be exceeded up to 6.5V maximum if the output current rating is observed.

### 6.2 ESD Ratings<sup>(1) (2)</sup>

ESD		Value	Unit
V(ESD)	Electrostatic discharge	Human-Body Model (HBM) <sup>(1)</sup>	8 K
		Charged-Device Model(CDM) <sup>(2)</sup>	2 K

(1)JEDEC document JEP155 states that 500-V HBM allows safe manufacturing with a standard ESD control process.

(2)JEDEC document JEP157 states that 250-V CDM allows safe manufacturing with a standard ESD control process.

## 6 Voltage, Temperature, ESD and Thermal Ratings(Continued)

### 6.3 Recommended Operating Conditions<sup>(1)</sup> <sup>(2)</sup> <sup>(3)</sup> <sup>(4)</sup>

			V <sub>CCI</sub>	V <sub>CCO</sub>	Min	Max	Unit
V <sub>CCA</sub>	Supply Voltage				1.65	5.5	V
V <sub>CCB</sub>					1.65	5.5	
V <sub>IH</sub>	High-level Input Voltage	Data Inputs	1.65V to 1.95V		V <sub>CCI</sub> × 0.65		V
			2.3V to 2.7V		1.7		
			3V to 3.6V		2		
			4.5V to 5.5V		V <sub>CCI</sub> × 0.7		
V <sub>IL</sub>	Low-level Input Voltage	Data Inputs	1.65V to 1.95V			V <sub>CCI</sub> × 0.35	V
			2.3V to 2.7V			0.7	
			3V to 3.6V			0.8	
			4.5V to 5.5V			V <sub>CCI</sub> × 0.3	
V <sub>IH</sub>	High-level Input Voltage	Control Inputs (referenced to V <sub>CCA</sub> )	1.65V to 1.95V		V <sub>CCA</sub> × 0.65		V
			2.3V to 2.7V		1.7		
			3V to 3.6V		2		
			4.5V to 5.5V		V <sub>CCA</sub> × 0.7		
V <sub>IL</sub>	Low-level Input Voltage	Control Inputs (referenced to V <sub>CCA</sub> )	1.65V to 1.95V			V <sub>CCI</sub> × 0.35	V
			2.3V to 2.7V			0.7	
			3V to 3.6V			0.8	
			4.5V to 5.5V			V <sub>CCI</sub> × 0.3	
V <sub>I</sub>	Input Voltage	Control Inputs			0	5.5	V
V <sub>I/O</sub>	Input/Output voltage	Active State			0	V <sub>CCO</sub>	V
		3-State			0	5.5	V
I <sub>OH</sub>	High-Level Output Current		1.65V to 1.95V			-4	mA
			2.3V to 2.7V			-8	
			3V to 3.6V			-24	
			4.5V to 5.5V			-32	
I <sub>OL</sub>	Low-Level Output Current		1.65V to 1.95V			4	mA
			2.3V to 2.7V			8	
			3V to 3.6V			24	
			4.5V to 5.5V			32	
Δt/Δv	Input Transition rise or fall	Data Inputs	1.65V to 1.95V			20	ns/V
			2.3V to 2.7V			20	
			3V to 3.6V			10	
			4.5V to 5.5V			5	
T <sub>A</sub>	Operating Free-Air Temperature				-40	+125	°C

(1)V<sub>CCI</sub> is the VCC associated with the data input port.

(2)V<sub>CCO</sub> is the VCC associated with the output port .

(3)For V<sub>CCI</sub> Values not specified in the data sheet, V<sub>IH</sub> min=V<sub>CCI</sub> × 0.7V, V<sub>IL</sub> max=V<sub>CCI</sub> × 0.3V .

(4)For V<sub>CCA</sub> Values not specified in the data sheet, V<sub>IH</sub> min=V<sub>CCA</sub> × 0.7V, V<sub>IL</sub> max=V<sub>CCA</sub> × 0.3V.

## 7 Electrical Specifications

### 7.1 Electrical Characteristics<sup>(1) (2)</sup>

over recommended operating free-air temperature range (unless otherwise noted)

Parameter		Test Conditions	VCCA	VCCB	Min	Typ	Max	Unit
VOH		IOH=-100 $\mu$ A, (VI=VIH)	1.65V to 4.5V	1.65V to 4.5V	VCCO-0.1			V
		IOH=-4 mA, (VI=VIH)	1.65V	1.65V	1.2			
		IOH=-8 mA, (VI=VIH)	2.3V	2.3V	1.9			
		IOH=-24 mA, (VI=VIH)	3V	3V	2.4			
		IOH=-32 mA, (VI=VIH)	4.5V	4.5V	3.8			
VOL		IOL=100 $\mu$ A, (VI=VIL)	1.65V to 4.5V	1.65V to 4.5V			0.1	V
		IOL=4 mA, (VI=VIL)	1.65V	1.65V			0.45	
		IOL=8 mA, (VI=VIL)	2.3V	2.3V			0.3	
		IOL=24 mA, (VI=VIL)	3V	3V			0.55	
		IOL=32 mA, (VI=VIL)	4.5V	4.5V			0.55	
II	DIR	VI=VCCA or GND	1.65V to 5.5V	1.65V to 5.5V			$\pm$ 2	$\mu$ A
Ioff	A or B Port	VI or VO=0 to 5.5V	0V	0 to 5.5V			$\pm$ 2	$\mu$ A
			0 to 5.5V	0V			$\pm$ 2	$\mu$ A
Ioz	A or B Port	VO=VCCO or GND, OEB=VIH	1.65V to 5.5V	1.65V to 5.5V			$\pm$ 2	$\mu$ A
ICCA		VI=VCCI or GND, IO=0	1.65V to 5.5V	1.65V to 5.5V			15	$\mu$ A
			5V	0V			15	
			0V	5V			-2	
ICCB		VI=VCCI or GND, IO=0	1.65V to 5.5V	1.65V to 5.5V			15	$\mu$ A
			5V	0V			-2	
			0V	5V			15	
ICCA + ICCB		VI=VCCI or GND, IO=0	1.65V to 5.5V	1.65V to 5.5V			25	$\mu$ A
$\Delta$ ICCA	A Port	One A Port at VCCA-0.6V, DIR at VCCA, B Port=Open	3V to 5.5V	3V to 5.5V			50	$\mu$ A
	DIR	DIR at VCCA-0.6V, B Port=Open, A Port at VCCA or GND					50	
$\Delta$ ICCB	B Port	One B Port at VCCB-0.6V, DIR at GND, A Port=Open	3V to 5.5V	3V to 5.5V			50	$\mu$ A
Ci	Control Inputs	VI=VCCA or GND	3.3V	3.3V		4	5	pF
Cio	A or B Port	VO=VCCA/B or GND	3.3V	3.3V		8.5	10	pF

(1)VCCO is the VCC associated with the output port.

(2)VCCI is the VCC associated with the input port.

## 7 Electrical Specifications(Continued)

### 7.2 Switching Characteristics, $V_{CCA}=1.8V\pm 0.15V$

over recommended operating free-air temperature range,  $V_{CCA}=1.8V\pm 0.15V$  (unless otherwise noted)

Parameter	From (Input)	To (Output)	$V_{CCB}=1.8V\pm 0.15V$		$V_{CCB}=2.5V\pm 0.2V$		$V_{CCB}=3.3V\pm 0.3V$		$V_{CCB}=5V\pm 0.5V$		Unit
			Min	Max	Min	Max	Min	Max	Min	Max	
TPLH	A	B	7.4	10.3	5.3	5.8	5.0	5.4	4.9	5.1	ns
TPHL											
TPLH	B	A	7.4	10.4	5.6	7.7	5.2	7.2	4.8	6.9	ns
TPHL											
TPHZ	OEB	A	11.0	11.8	8.3	12.0	7.6	12.3	6.6	12.7	ns
TPLZ											
TPHZ	OEB	B	10.5	12.3	9.9	10.5	9.9	10.6	10.6	11.3	ns
TPLZ											
TPZH	OEB	A	11.5	14.6	11.4	14.0	11.3	14.0	11.8	15.8	ns
TPZL											
TPZH	OEB	B	14.4	17.9	9.8	11.5	9.0	10.9	9.3	11.3	ns
TPZL											

### 7.3 Switching Characteristics, $V_{CCA}=2.5V\pm 0.2V$

over recommended operating free-air temperature range,  $V_{CCA}=2.5V\pm 0.2V$  (unless otherwise noted)

Parameter	From (Input)	To (Output)	$V_{CCB}=1.8V\pm 0.15V$		$V_{CCB}=2.5V\pm 0.2V$		$V_{CCB}=3.3V\pm 0.3V$		$V_{CCB}=5V\pm 0.5V$		Unit
			Min	Max	Min	Max	Min	Max	Min	Max	
TPLH	A	B	5.7	7.5	2.9	3.9	2.5	3.3	2.3	2.9	ns
TPHL											
TPLH	B	A	5.3	6.1	2.9	3.9	2.4	3.5	1.9	3.2	ns
TPHL											
TPHZ	OEB	A	5.5	6.9	5.4	6.8	3.2	6.7	2.8	6.6	ns
TPLZ											
TPHZ	OEB	B	7.6	9.1	5.0	7.5	4.1	7.2	5.2	7.2	ns
TPLZ											
TPZH	OEB	A	4.6	10.8	4.7	6.4	4.7	6.5	5.0	7.0	ns
TPZL											
TPZH	OEB	B	11.6	13.4	5.6	7.3	4.6	6.1	4.0	5.2	ns
TPZL											



## 7 Electrical Specifications(Continued)

### 7.4 Switching Characteristics, $V_{CCA}=3.3V\pm 0.3V$

over recommended operating free-air temperature range,  $V_{CCA}=3.3V\pm 0.3V$  (unless otherwise noted)

Parameter	From (Input)	To (Output)	$V_{CCB}=1.8V\pm 0.15V$		$V_{CCB}=2.5V\pm 0.2V$		$V_{CCB}=3.3V\pm 0.3V$		$V_{CCB}=5V\pm 0.5V$		Unit
			Min	Max	Min	Max	Min	Max	Min	Max	
TPLH	A	B	5.2	7.0	2.4	3.5	2.0	2.9	1.8	2.5	ns
TPHL											
TPLH	B	A	5.3	6.1	2.9	3.9	2.4	3.5	1.9	3.2	ns
TPHL											
TPHZ	OEB	A	4.3	5.8	4.4	5.9	4.3	5.5	2.1	4.8	ns
TPLZ											
TPHZ	OEB	B	6.0	8.8	4.7	6.8	3.2	6.3	3.3	5.9	ns
TPLZ											
TPZH	OEB	A	3.3	10.0	3.4	6.0	3.4	4.8	3.4	5.4	ns
TPZL											
TPZH	OEB	B	11.2	13.0	5.0	6.8	3.9	5.5	3.3	4.6	ns
TPZL											

### 7.5 Switching Characteristics, $V_{CCA}=5V\pm 0.5V$

over recommended operating free-air temperature range,  $V_{CCA}=5V\pm 0.5V$  (unless otherwise noted)

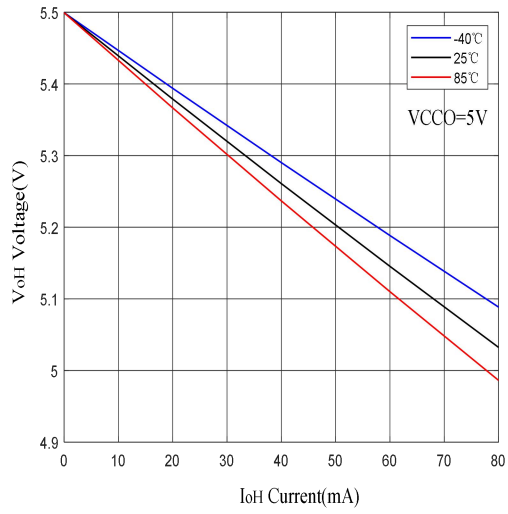
Parameter	From (Input)	To (Output)	$V_{CCB}=1.8V\pm 0.15V$		$V_{CCB}=2.5V\pm 0.2V$		$V_{CCB}=3.3V\pm 0.3V$		$V_{CCB}=5V\pm 0.5V$		Unit
			Min	Max	Min	Max	Min	Max	Min	Max	
TPLH	A	B	4.9	6.7	1.9	3.3	1.6	2.7	1.4	2.3	ns
TPHL											
TPLH	B	A	5.2	5.7	2.3	3.0	1.8	2.6	1.3	2.3	ns
TPHL											
TPHZ	OEB	A	3.3	4.3	3.1	3.8	3.3	4.5	2.6	3.7	ns
TPLZ											
TPHZ	OEB	B	3.3	9.5	3.8	4.9	3.3	4.3	1.7	3.8	ns
TPLZ											
TPZH	OEB	A	2.6	9.6	2.6	7.2	2.6	4.8	2.6	3.9	ns
TPZL											
TPZH	OEB	B	10.6	12.3	5.3	6.7	3.7	5.4	3.5	4.2	ns
TPZL											

### 7.6 Operating Characteristics

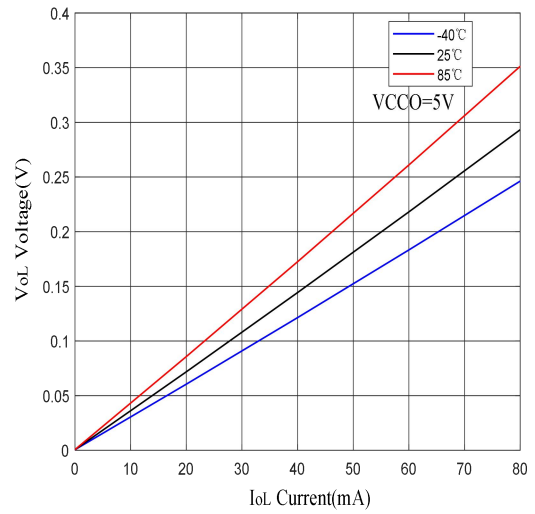
$T_A=25^\circ C$

Parameter		Test Conditions	$V_{CCA}=V_{CCB}=1.8V$	$V_{CCA}=V_{CCB}=2.5V$	$V_{CCA}=V_{CCB}=3.3V$	$V_{CCA}=V_{CCB}=5V$	Unit
			Typ	Typ	Typ	Typ	
CpdA	A-port Input, B-port Output	CL=0, f=10 MHz, tr=tf=1 ns	2.4	2.6	2.9	3.7	pF
	B-port Input, A-port Output		16.7	17.3	17.9	22.6	
CpdB	A-port Input, B-port Output		16.4	17.1	17.8	22.5	
	B-port Input, A-port Output		2.4	2.6	2.9	3.9	

## 8 Typical Characteristics

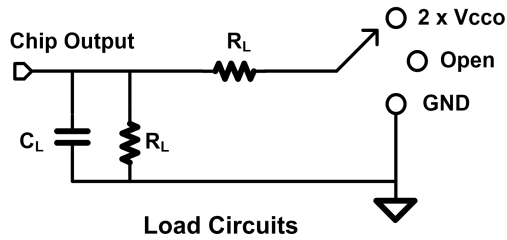


**Fig.8-1. Voltage Vs Current**

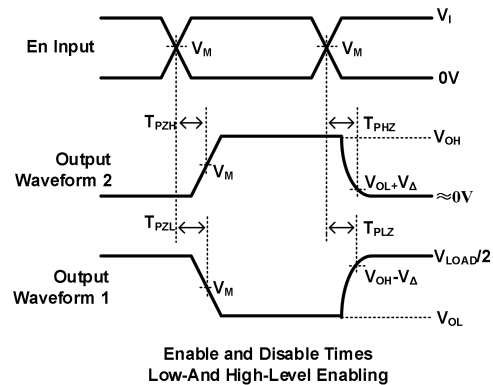
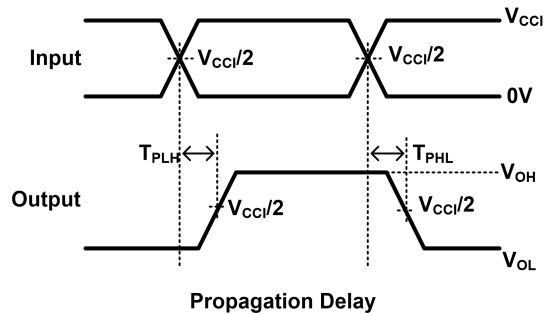


**Fig.8-2. Voltage Vs Current**

## 9 Parameter Measurement Information



Parameter	Vcco	RL	CL	S1	VTP
$T_{pd}$ Propagation delay time	1.8V-5.5V	2 k $\Omega$	15 pF	Open	N/A
$T_{PLZ}, T_{PZL}$ Enable time, disable time	$1.8V \pm 0.15V$	2 k $\Omega$	15 pF	2 xVcco	0.15V
	$2.5V \pm 0.2V$	2 k $\Omega$	15 pF	2 xVcco	0.15V
	$3.3V \pm 0.3V$	2 k $\Omega$	15 pF	2 xVcco	0.3V
	$5V \pm 0.5V$	2 k $\Omega$	15 pF	2 xVcco	0.3V
$T_{PHZ}, T_{PZH}$ Enable time, disable time	$1.8V \pm 0.15V$	2 k $\Omega$	15 pF	GND	0.15V
	$2.5V \pm 0.2V$	2 k $\Omega$	15 pF	GND	0.15V
	$3.3V \pm 0.3V$	2 k $\Omega$	15 pF	GND	0.3V
	$5V \pm 0.5V$	2 k $\Omega$	15 pF	GND	0.3V



**Notes:**

- A. CL includes probe and jig capacitance.
- B. Waveform 1 is for an output with internal conditions such that the output is low, except when disabled by the output control. Waveform 2 is for an output with internal conditions such that the output is high, except when disabled by the output control.
- C. All input pulses are supplied by generators having the following characteristics:  $PRR \leq 10$  MHz,  $ZO = 50 \Omega$ ,  $dv/dt \geq 1V/ns$ .
- D. The outputs are measured one at a time, with one transition per measurement.
- E. TPLZ and TPHZ are the same as tdis .
- F. TPZL and TPZH are the same as ten .
- G. TPLH and TPHL are the same as tpd .
- H. VCCI is the VCC associated with the input port.
- I. VCCO is the VCC associated with the output port.
- J. All parameters and waveforms are not applicable to all devices.

## 10 Detailed Description

The GT74LVC4T245 is a 4-bit, dual supply non-inverting Voltage level translation. Pin Ax and direction control pin are support by  $V_{CCA}$  and pin Bx is support by  $V_{CCB}$ . The A port is able to accept I/O Voltages ranging from 1.65V to 5.5V, while the B port can accept I/O Voltages from 1.65V to 5.5V. The high on DIR allows data transmission from A to B and a low on DIR allows data transmission from B to A.

This device is fully specified for partial-power-down applications using  $I_{off}$ . The  $I_{off}$  circuitry disables the outputs, preventing damaging current backflow through the device when it is powered down.

The VCC isolation feature ensures that if either VCC input is at GND, all outputs are in the high-impedance state.

To ensure the high-impedance state during power up or power down, OEB should be tied to VCC through a pullup resistor; the minimum Value of the resistor is determined by the current-sinking capability of the driver.

The GT74LVC4T245 is a Voltage level translator that can operate from 1.65V to 5.5V ( $V_{CCA}$ ) and 1.65V to 5.5V ( $V_{CCB}$ ). The signal translation between 1.65V and 5.5V requires direction control and output enable control. When OEB is low and DIR is high, data transmission is from A to B. When OEB is low and DIR is low, data transmission is from B to A. When OEB is high, both output ports will be high-impedance.

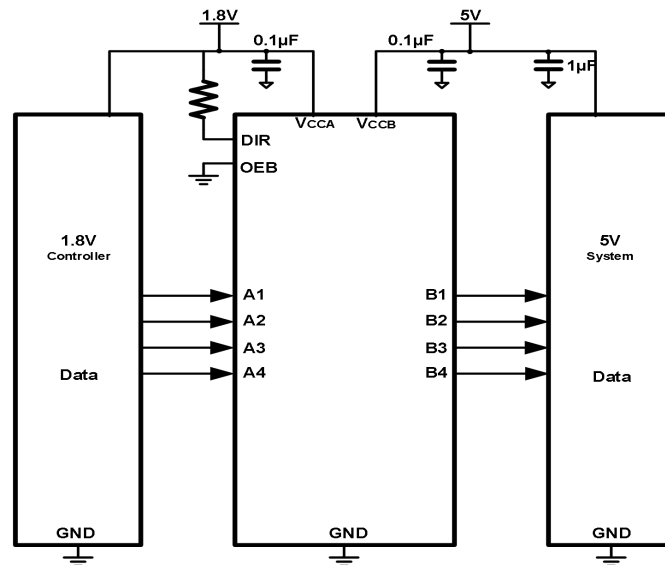
**Table.10-1. Function Table**

Control Inputs		Output Circuits		Operation
OEB	DIR	A port	B port	
L	L	Enabled	Hi-Z	B TO A
L	H	Hi-Z	Enabled	A TO B
H	X	Hi-Z	Hi-Z	Isolation

## 11 Application Note

The GT74LVC4T245 device can be used in level-translation applications for interfacing devices or systems operating at different interface voltages with one another. The maximum output current can be up to 32 mA when device is powered by 5 V.

### 11.1 Typical Application



**Fig.11-1. Typical Application Circuit**

### 11.2 Enable Times

$TPZH (DIR \text{ to } A) = TPLZ (DIR \text{ to } B) + TPLH (B \text{ to } A)$

$TPZL (DIR \text{ to } A) = TPHZ (DIR \text{ to } B) + TPHL (B \text{ to } A)$

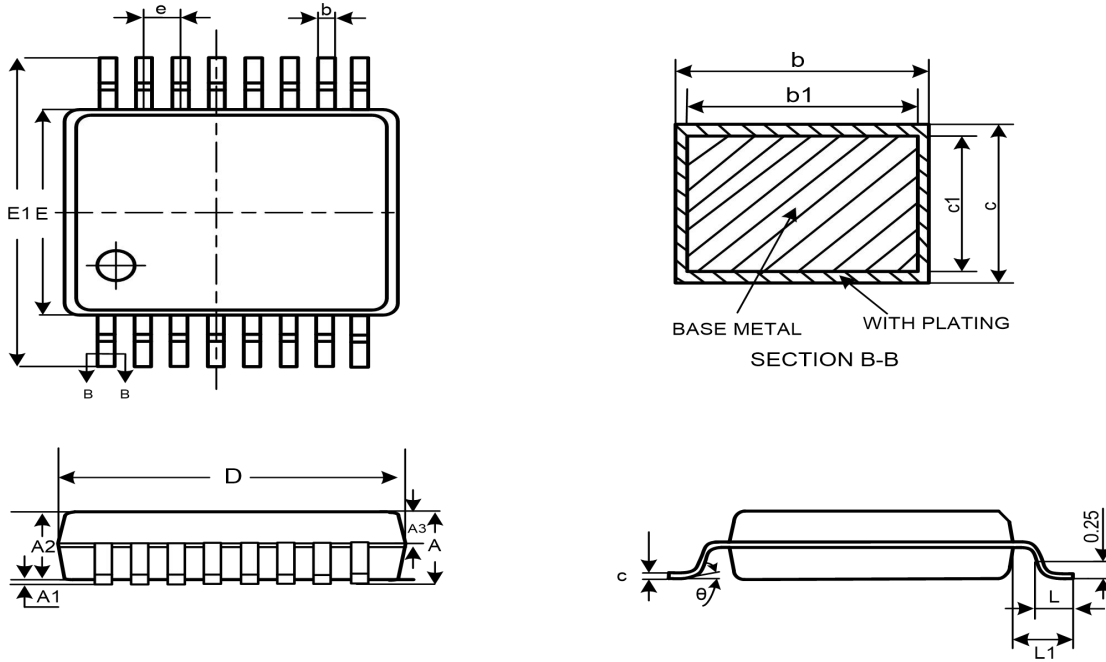
$TPZH (DIR \text{ to } B) = TPLZ (DIR \text{ to } A) + TPLH (A \text{ to } B)$

$TPZL (DIR \text{ to } B) = TPHZ (DIR \text{ to } A) + TPHL (A \text{ to } B)$

In a bidirectional application, these enable times provide the maximum delay from the time the DIR bit is switched until an output is expected. For example, if the GT74LVC4T245 initially is transmitting from A to B, then the DIR bit is switched; the B port of the device must be disabled before presenting it with an input. After the B port has been disabled, an input signal applied to it appears on the corresponding A port after the specified propagation delay.

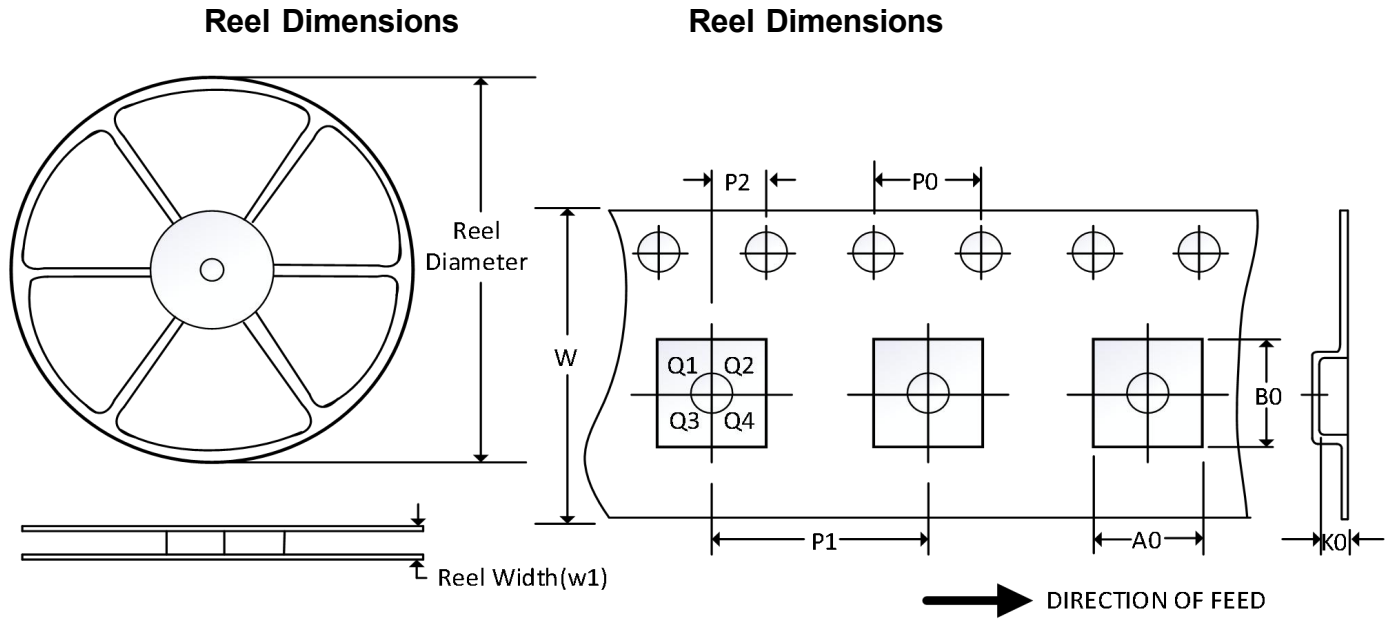
# 12 Package Outline Dimension

TSSOP16



Symbol	Dimensions In Millimeters			Dimensions In Inches		
	Min	Nom	Min	Nom	Min	Nom
A	—	—	1.20	—	—	0.047
A1	0.05	—	0.15	0.002	—	0.006
A2	0.80	1.00	1.05	0.031	0.039	0.041
A3	0.39	0.44	0.49	0.015	0.017	0.019
b	0.19	—	0.30	0.007	—	0.012
b1	0.19	0.22	0.25	0.007	0.009	0.010
c	0.13	—	0.18	0.005	—	0.007
c1	0.12	0.13	0.14	0.005	0.005	0.006
D	4.86	4.98	5.10	0.191	0.196	0.201
E	4.30	4.40	4.50	0.169	0.173	0.177
E1	6.20	6.40	6.60	0.244	0.252	0.260
e	0.65BSC			0.026BSC		
L	0.45	0.60	0.75	0.018	0.024	0.030
L1	1.00BSC			0.039BSC		
θ	0°	—	8°	0°	—	8°

### 13 Tape and Reel Information



Note: The picture is only for reference. Please make the object as the standard.

#### Key Parameter List of Tape and Reel

Package Type	Reel Diameter	Reel Width (mm)	A0 (mm)	B0 (mm)	K0 (mm)	P0 (mm)	P1 (mm)	P2 (mm)	W (mm)	Pin1 Quadrant
TSSOP16	13"	12.4	6.90	5.60	1.20	4.0	8.0	2.0	12.0	Q1

Note:  
 (1) All dimensions are nominal.  
 (2) Plastic or metal protrusions of 0.15mm maximum per side are not included.