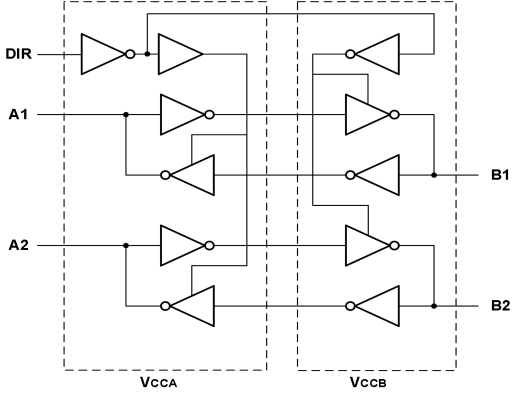

GT74LVC2T45

Dual-bit Dual-Supply Bus Transceiver with Voltage Translation

1 Features	2 Application
<ul style="list-style-type: none"> - Control inputs V_{IH}/V_{IL} levels are referenced to V_{CCA} - Vcc isolation feature – if either Vcc input is at GND, all are in the high-impedance state - Fully configurable dual-rail design allows each port to operate over the full 1.65V to 5.5V power supply range - Recommended temperature range: -40°C to $+125^{\circ}\text{C}$ - Max data rates 420 Mbps (3.3-V to 5-V Translation) 210 Mbps (Translate to 3.3V) 140 Mbps (Translate to 2.5V) 75 Mbps (Translate to 1.8V) 	<ul style="list-style-type: none"> - Personal Electronic - Industrial - Enterprise - Telecom

3 Description	Circuit Diagram
<p>This dual-bit noninverting bus transceiver uses two separate power-supply rails. The GT74LVC2T45 is optimized to operate with V_{CCA} and V_{CCB} set at 1.65V to 5.5V. The A port is designed to track V_{CCA}. V_{CCA} accepts any supply voltage from 1.65V to 5.5V. The B port is designed to track V_{CCB}. V_{CCB} accepts any supply voltage from 1.65V to 5.5V. This allows for universal low-voltage bidirectional translation between any of the 1.8 V, 2.5 V, 3.3 V, and 5.5V voltage nodes. The logic levels of the direction-control (DIR) input activate either the B-port outputs or the A-port outputs. The device transmits data from the A bus to the B bus when the B-port outputs are activated, and from the B bus to the A bus when the A-port outputs are activated. The input circuitry on both A and B ports is always active and have a logic HIGH or LOW level applied to prevent excess I_{CC} and I_{CCZ}. The GT74LVC2T45 is designed so that the control pin (DIR) is supplied by V_{CCA}.</p>	 <p>The circuit diagram shows the internal structure of the GT74LVC2T45. It features two input ports, A1 and A2, and two output ports, B1 and B2. A direction-control input, DIR, is shown at the top left. The device is powered by two separate supply rails, V_{CCA} and V_{CCB}, which are indicated by dashed boxes at the bottom. The DIR input is connected to a network of inverters and buffers that control the direction of data flow between the A and B buses. The A bus is connected to V_{CCA} and the B bus is connected to V_{CCB}.</p>

4 Revision History

Revision	Date	Note
Rev. A1. 0	2023. 10. 21	Original Version
Rev. A1. 1	2023. 11. 02	1.Update Package Qty 2.Added Tape and Reel Information
Rev. A1. 2	2023. 12. 26	1. Added Marking 2.Added MSL
Rev. A1. 3	2024. 01. 26	Updated Part Name
Rev. A1. 4	2024. 12. 13	Updated Marking and Package Qty

The latest datasheet version should be checked on the GTIC official website, as the company does not actively inform customers about updates to the datasheet.

5 Device Summary, Pin and Packages

Table.5-1. Device Summary⁽¹⁾

Serial Name	Part Name	Package	Body Size (Nom)	Marking ⁽²⁾	MSL ⁽³⁾	Package Qty
GT74LVC2T45	GT74LVC2T45V8	VSSOP8	3.20mmx2.10mmx1.90mm	2T45 XXXX	3	Tape and Reel,3000
GT74LVC2T45	GT74LVC2T45M8	MSOP8	3.00mmx3.00mmx1.10mm	74LVC2T45 XXXXXXX	3	Tape and Reel,4000

(1)For all available packages, please contact product sales.

(2)There may be additional marking, which relates to the lot trace code information (data code and Vendor code), the logo or the environmental category on the device.

(3)MSL, The Moisture Sensitivity Level rating according to the JEDEC industry standard classifications.

(4)"XXXXX" in Marking will be appeared as the batch code.

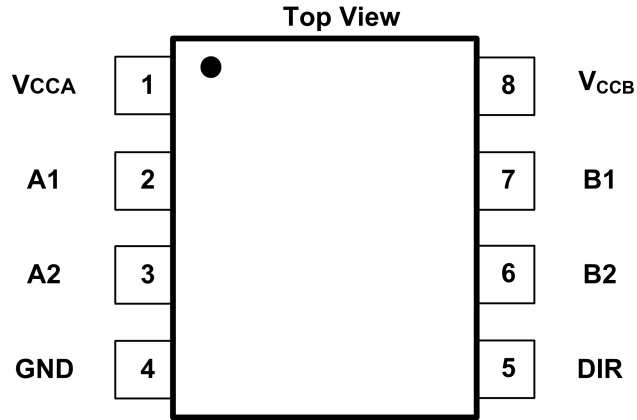
5 Device Summary, Pin and Packages(Continued)

**Fig.5-1. GT74LVC2T45: V8 (VSSOP8) Package
GT74LVC2T45: M8 (MSOP8) Package**

Table.5-2. Pin Definition

PIN		I/O	Description
Name	V8 M8		
VCCA	1	-	A-port supply voltage. $1.65V \leq VCCA \leq 5.5 V$
A1	2	I/O	Input/output A1. Referenced to VCCA
A2	3	I/O	Input/output A2. Referenced to VCCA
GND	4	-	Ground
DIR	5	I	Direction control signal
B2	6	I/O	Input/output B2. Referenced to VCCB
B1	7	I/O	Input/output B1. Referenced to VCCB
VCCB	8	-	B-port supply voltage. $1.65V \leq VCCB \leq 5.5 V$

* All unused input pins cannot be suspended and suggested to connect to GND.

6 Voltage, Temperature, ESD and Thermal Ratings

6.1 Absolute Maximum Ratings⁽¹⁾

Parameters			MIN	MAX	UNIT
Supply voltage range, VCCA, VCCB			-0.5	6.5	V
VI	Input voltage range ⁽²⁾	I/O ports (A port)	-0.5	6.5	V
		I/O ports (B port)	-0.5	6.5	
		Control inputs	-0.5	6.5	
VO	Voltage range applied to any output in the high-impedance or power-off state ⁽²⁾	A port	-0.5	6.5	V
		B port	-0.5	6.5	
VO	Voltage range applied to any output in the high or low state ⁽²⁾ ⁽³⁾	A port	-0.5	VCCA + 0.5	V
		B port	-0.5	VCCB + 0.5	
I _{IK}	Input clamp current	VI < 0		-50	mA
I _{OK}	Output clamp current	VO < 0		-50	mA
IO	Continuous output current			±50	mA
Continuous current through each VCCA, VCCB, and GND				±100	mA

(1)Stresses beyond those listed under "absolute maximum ratings" may cause permanent damage to the device. These are stress ratings only, and functional operation of the device at these or any other conditions beyond those indicated under "recommended operating conditions" is not implied. Exposure to absolute-maximum-rated conditions for extended periods may affect device reliability.

(2)The input and output negative-voltage ratings may be exceeded if the input and output current ratings are observed.

(3)The output positive-voltage rating may be exceeded up to 6.5V maximum if the output current rating is observed.

6.2 ESD Ratings^{(1) (2)}

ESD		Value	Unit
V(ESD)	Electrostatic discharge	Human-Body Model (HBM)	8 K
		Charged-Device Model(CDM)	2 K

(1)JEDEC document JEP155 states that 500-V HBM allows safe manufacturing with a standard ESD control process.

(2)JEDEC document JEP157 states that 250-V CDM allows safe manufacturing with a standard ESD control process.

6 Voltage, Temperature, ESD and Thermal Ratings(Continued)

6.3 Recommended Operating Conditions⁽¹⁾ ⁽²⁾ ⁽³⁾ ⁽⁴⁾

			V _{CCI}	V _{CCO}	MIN	MAX	UNIT
V _{CCA}	Supply Voltage				1.65	5.5	V
V _{CCB}					1.65	5.5	
V _{IH}	High-level Input Voltage	Data Inputs	1.65V to 1.95V		V _{CCI} × 0.65		V
			2.3V to 2.7V		1.7		
			3V to 3.6V		2		
			4.5V to 5.5V		V _{CCI} × 0.7		
V _{IL}	Low-level Input Voltage	Data Inputs	1.65V to 1.95V			V _{CCI} × 0.35	V
			2.3V to 2.7V			0.7	
			3V to 3.6V			0.8	
			4.5V to 5.5V			V _{CCI} × 0.3	
V _{IH}	High-level Input Voltage	Control Inputs (referenced to V _{CCA})	1.65V to 1.95V		V _{CCA} × 0.65		V
			2.3V to 2.7V		1.7		
			3V to 3.6V		2		
			4.5V to 5.5V		V _{CCA} × 0.7		
V _{IL}	Low-level Input Voltage	Control Inputs (referenced to V _{CCA})	1.65V to 1.95V			V _{CCI} × 0.35	V
			2.3V to 2.7V			0.7	
			3V to 3.6V			0.8	
			4.5V to 5.5V			V _{CCI} × 0.3	
V _I	Input Voltage	Control Inputs			0	5.5	V
V _{I/O}	Input/Output voltage	Active State			0	V _{CCO}	V
		3-State			0	5.5	V
I _{OH}	High-Level Output Current		1.65V to 1.95V			-4	mA
			2.3V to 2.7V			-8	
			3V to 3.6V			-24	
			4.5V to 5.5V			-32	
I _{OL}	Low-Level Output Current		1.65V to 1.95V			4	mA
			2.3V to 2.7V			8	
			3V to 3.6V			24	
			4.5V to 5.5V			32	
Δt/Δv	Input Transition rise or fall	Data Inputs	1.65V to 1.95V			20	ns/V
			2.3V to 2.7V			20	
			3V to 3.6V			10	
			4.5V to 5.5V			5	
T _A	Operating Free-Air Temperature				-40	+125	°C

(1)V_{CCI} is the V_{CC} associated with the data input port.

(2)V_{CCO} is the V_{CC} associated with the output port .

(3)For V_{CCI} Values not specified in the data sheet, V_{IH} min=V_{CCI} × 0.7V, V_{IL} max=V_{CCI} × 0.3V .

(4)For V_{CCA} Values not specified in the data sheet, V_{IH} min=V_{CCA} × 0.7V, V_{IL} max=V_{CCA} × 0.3V.

7 Electrical Specifications

7.1 Electrical Characteristics^{(1) (2)}

over recommended operating free-air temperature range (unless otherwise noted)

Parameter		Test Conditions	V _{CCA}	V _{CCB}	Min	Typ	Max	Unit
V _{OH}		I _{OH} =-100 μA, (V _I =V _{IH})	1.65V to 4.5V	1.65V to 4.5V	V _{CCO} -0.1			V
		I _{OH} =-4 mA, (V _I =V _{IH})	1.65V	1.65V	1.2			
		I _{OH} =-8 mA, (V _I =V _{IH})	2.3V	2.3V	1.9			
		I _{OH} =-24 mA, (V _I =V _{IH})	3V	3V	2.4			
		I _{OH} =-32 mA, (V _I =V _{IH})	4.5V	4.5V	3.8			
V _{OL}		I _{OL} =100 μA, (V _I =V _{IL})	1.65V to 4.5V	1.65V to 4.5V			0.1	V
		I _{OL} =4 mA, (V _I =V _{IL})	1.65V	1.65V			0.45	
		I _{OL} =8 mA, (V _I =V _{IL})	2.3V	2.3V			0.3	
		I _{OL} =24 mA, (V _I =V _{IL})	3V	3V			0.55	
		I _{OL} =32 mA, (V _I =V _{IL})	4.5V	4.5V			0.55	
I _I	DIR	V _I =V _{CCA} or GND	1.65V to 5.5V	1.65V to 5.5V			±2	μA
I _{off}	A or B Port	V _I or V _O =0 to 5.5V	0V	0 to 5.5V			±2	μA
			0 to 5.5V	0V			±2	
I _{OZ}	A or B Port	V _O =V _{CCO} or GND, OEB=V _{IH}	1.65V to 5.5V	1.65V to 5.5V			±2	μA
I _{CCA}		V _I =V _{CCi} or GND, I _O =0	1.65V to 5.5V	1.65V to 5.5V			15	μA
			5V	0V			15	
			0V	5V			-2	
I _{CCB}		V _I =V _{CCi} or GND, I _O =0	1.65V to 5.5V	1.65V to 5.5V			15	μA
			5V	0V			-2	
			0V	5V			15	
I _{CCA} + I _{CCB}		V _I =V _{CCi} or GND, I _O =0	1.65V to 5.5V	1.65V to 5.5V			25	μA
ΔI _{CCA}	A Port	One A Port at V _{CCA} -0.6V, DIR at V _{CCA} , B Port=Open	3V to 5.5V	3V to 5.5V			50	μA
	DIR	DIR at V _{CCA} -0.6V, B Port=Open, A Port at V _{CCA} or GND					50	
ΔI _{CCB}	B Port	One B Port at V _{CCB} -0.6V, DIR at GND, A Port=Open	3V to 5.5V	3V to 5.5V			50	μA
C _i	Control Inputs	V _I =V _{CCA} or GND	3.3V	3.3V		4	5	pF
C _{io}	A or B Port	V _O =V _{CCA/B} or GND	3.3V	3.3V		8.5	10	pF

(1)V_{CCO} is the V_{CC} associated with the output port.

(2)V_{CCi} is the V_{CC} associated with the input port.

7 Electrical Specifications(Continued)

7.2 Switching Characteristics, $V_{CCA}=1.8V\pm 0.15V$

over recommended operating free-air temperature range, $V_{CCA}=1.8V\pm 0.15V$ (unless otherwise noted)

Parameter	From (Input)	To (Output)	$V_{CCB}=1.8V\pm 0.15V$		$V_{CCB}=2.5V\pm 0.2V$		$V_{CCB}=3.3V\pm 0.3V$		$V_{CCB}=5V\pm 0.5V$		Unit
			Min	Max	Min	Max	Min	Max	Min	Max	
TPLH	A	B	7.4	10.3	5.3	5.8	5.0	5.4	4.9	5.1	ns
TPHL											
TPLH	B	A	7.4	10.4	5.6	7.7	5.2	7.2	4.8	6.9	ns
TPHL											
TPHZ	OEB	A	11.0	11.8	8.3	12.0	7.6	12.3	6.6	12.7	ns
TPLZ											
TPHZ	OEB	B	10.5	12.3	9.9	10.5	9.9	10.6	10.6	11.3	ns
TPLZ											
TPZH	OEB	A	11.5	14.6	11.4	14.0	11.3	14.0	11.8	15.8	ns
TPZL											
TPZH	OEB	B	14.4	17.9	9.8	11.5	9.0	10.9	9.3	11.3	ns
TPZL											

7.3 Switching Characteristics, $V_{CCA}=2.5V\pm 0.2V$

over recommended operating free-air temperature range, $V_{CCA}=2.5V\pm 0.2V$ (unless otherwise noted)

Parameter	From (Input)	To (Output)	$V_{CCB}=1.8V\pm 0.15V$		$V_{CCB}=2.5V\pm 0.2V$		$V_{CCB}=3.3V\pm 0.3V$		$V_{CCB}=5V\pm 0.5V$		Unit
			Min	Max	Min	Max	Min	Max	Min	Max	
TPLH	A	B	5.7	7.5	2.9	3.9	2.5	3.3	2.3	2.9	ns
TPHL											
TPLH	B	A	5.3	6.1	2.9	3.9	2.4	3.5	1.9	3.2	ns
TPHL											
TPHZ	OEB	A	5.5	6.9	5.4	6.8	3.2	6.7	2.8	6.6	ns
TPLZ											
TPHZ	OEB	B	7.6	9.1	5.0	7.5	4.1	7.2	5.2	7.2	ns
TPLZ											
TPZH	OEB	A	4.6	10.8	4.7	6.4	4.7	6.5	5.0	7.0	ns
TPZL											
TPZH	OEB	B	11.6	13.4	5.6	7.3	4.6	6.1	4.0	5.2	ns
TPZL											

7 Electrical Specifications(Continued)

7.4 Switching Characteristics, $V_{CCA}=3.3V\pm 0.3V$

over recommended operating free-air temperature range, $V_{CCA}=3.3V\pm 0.3V$ (unless otherwise noted)

Parameter	From (Input)	To (Output)	$V_{CCB}=1.8V\pm 0.15V$		$V_{CCB}=2.5V\pm 0.2V$		$V_{CCB}=3.3V\pm 0.3V$		$V_{CCB}=5V\pm 0.5V$		Unit
			Min	Max	Min	Max	Min	Max	Min	Max	
TPLH	A	B	5.2	7.0	2.4	3.5	2.0	2.9	1.8	2.5	ns
TPHL											
TPLH	B	A	5.3	6.1	2.9	3.9	2.4	3.5	1.9	3.2	ns
TPHL											
TPHZ	OEB	A	4.3	5.8	4.4	5.9	4.3	5.5	2.1	4.8	ns
TPLZ											
TPHZ	OEB	B	6.0	8.8	4.7	6.8	3.2	6.3	3.3	5.9	ns
TPLZ											
TPZH	OEB	A	3.3	10.0	3.4	6.0	3.4	4.8	3.4	5.4	ns
TPZL											
TPZH	OEB	B	11.2	13.0	5.0	6.8	3.9	5.5	3.3	4.6	ns
TPZL											

7.5 Switching Characteristics, $V_{CCA}=5V\pm 0.5V$

over recommended operating free-air temperature range, $V_{CCA}=5V\pm 0.5V$ (unless otherwise noted)

Parameter	From (Input)	To (Output)	$V_{CCB}=1.8V\pm 0.15V$		$V_{CCB}=2.5V\pm 0.2V$		$V_{CCB}=3.3V\pm 0.3V$		$V_{CCB}=5V\pm 0.5V$		Unit
			Min	Max	Min	Max	Min	Max	Min	Max	
TPLH	A	B	4.9	6.7	1.9	3.3	1.6	2.7	1.4	2.3	ns
TPHL											
TPLH	B	A	5.2	5.7	2.3	3.0	1.8	2.6	1.3	2.3	ns
TPHL											
TPHZ	OEB	A	3.3	4.3	3.1	3.8	3.3	4.5	2.6	3.7	ns
TPLZ											
TPHZ	OEB	B	3.3	9.5	3.8	4.9	3.3	4.3	1.7	3.8	ns
TPLZ											
TPZH	OEB	A	2.6	9.6	2.6	7.2	2.6	4.8	2.6	3.9	ns
TPZL											
TPZH	OEB	B	10.6	12.3	5.3	6.7	3.7	5.4	3.5	4.2	ns
TPZL											

7.6 Operating Characteristics

$T_A=25^\circ C$

Parameter		Test Conditions	$V_{CCA}=V_{CCB}=1.8V$	$V_{CCA}=V_{CCB}=2.5V$	$V_{CCA}=V_{CCB}=3.3V$	$V_{CCA}=V_{CCB}=5V$	Unit
			Typ	Typ	Typ	Typ	
CpdA	A-port Input, B-port Output	CL=0, f=10 MHz, tr=tf=1 ns	2.4	2.6	2.9	3.7	pF
	B-port Input, A-port Output		16.7	17.3	17.9	22.6	
CpdB	A-port Input, B-port Output		16.4	17.1	17.8	22.5	
	B-port Input, A-port Output		2.4	2.6	2.9	3.9	

8 Typical Characteristics

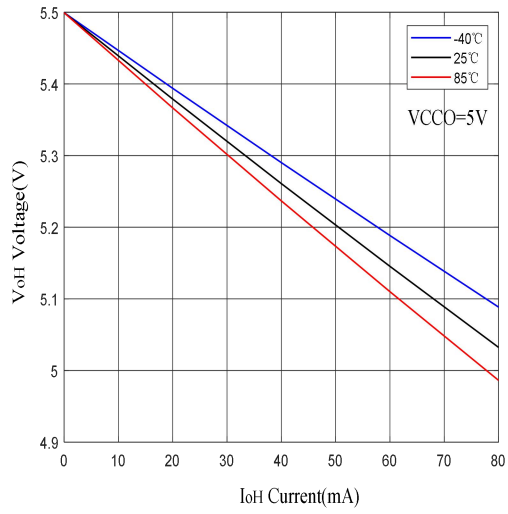

Fig.8-1. Voltage Vs Current

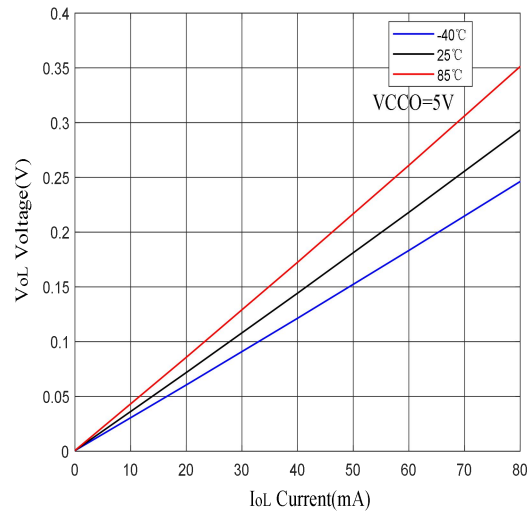
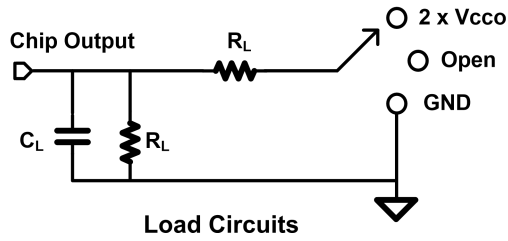

Fig.8-2. Voltage Vs Current

9 Parameter Measurement Information



Parameter	V _{CC0}	R _L	C _L	S1	VTP
T _{pd} Propagation delay time	1.8V-5.5V	2 kΩ	15 pF	Open	N/A
T _{PLZ} , T _{PZL} Enable time, disable time	1.8V ± 0.15V	2 kΩ	15 pF	2 X V _{CC0}	0.15V
	2.5V ± 0.2V	2 kΩ	15 pF	2 X V _{CC0}	0.15V
	3.3V ± 0.3V	2 kΩ	15 pF	2 X V _{CC0}	0.3V
	5V ± 0.5V	2 kΩ	15 pF	2 X V _{CC0}	0.3V
T _{PHZ} , T _{PZH} Enable time, disable time	1.8V ± 0.15V	2 kΩ	15 pF	GND	0.15V
	2.5V ± 0.2V	2 kΩ	15 pF	GND	0.15V
	3.3V ± 0.3V	2 kΩ	15 pF	GND	0.3V
	5V ± 0.5V	2 kΩ	15 pF	GND	0.3V

9 Parameter Measurement Information(Continued)

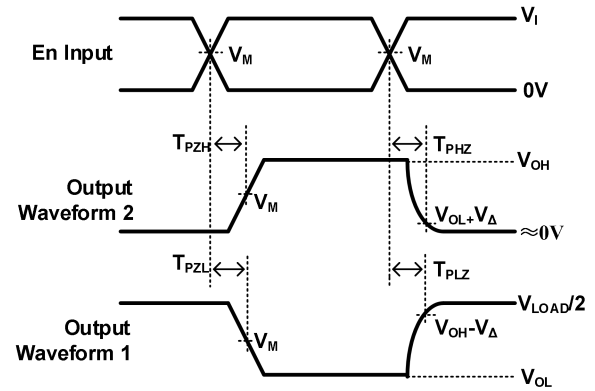
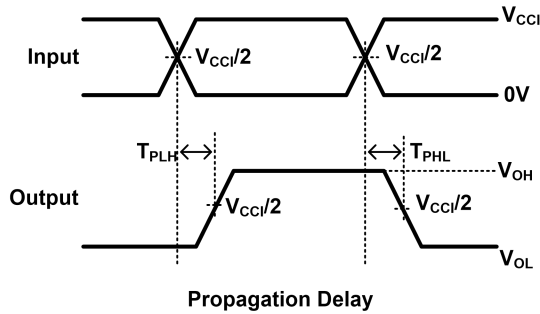

**Enable and Disable Times
Low-And High-Level Enabling**

Notes:

- A.CL includes probe and jig capacitance.
- B.Waveform 1 is for an output with internal conditions such that the output is low, except when disabled by the output control. Waveform 2 is for an output with internal conditions such that the output is high, except when disabled by the output control.
- C.All input pulses are supplied by generators having the following characteristics: PRR ≤ 10 MHz, Z_O = 50 Ω, dv/dt ≥ 1V/ns.
- D.The outputs are measured one at a time, with one transition per measurement.
- E.TPLZ and TPHZ are the same as tdis .
- F.TPZL and TPZH are the same as ten .
- G.TPLH and TPHL are the same as tpd .
- H.VCCI is the VCC associated with the input port.
- I.VCCO is the VCC associated with the output port.
- J.All parameters and waveforms are not applicable to all devices.

10 Detailed Description

The GT74LVC2T45 is a dual-bit, dual supply non-inverting voltage level translation. Pin A and direction control pin are support by VCCA and pin B is support by VCCB. The A port is able to accept I/O voltages ranging from 1.65Vto 5.5 V, while the B port can accept I/O voltages from 1.65Vto 5.5 V. The high on DIR allows data transmission from A to B and a low on DIR allows data transmission from B to A.

This device is fully specified for partial-power-down applications using Ioff. The Ioff circuitry disables the outputs, preventing damaging current backflow through the device when it is powered down.

The VCC isolation feature ensures that if either VCC input is at GND, all outputs are in the high-impedance state.

The GT74LVC2T45 is a voltage level translator that can operate from 1.65Vto 5.5V(VCCA) and 1.65Vto 5.5V(VCCB). The signal translation between 1.65Vand 5.5Vrequires direction control. When DIR is high, data transmission is from A to B. When DIR is low, data transmission is from B to A.

Table.10-1. Function Table

Control Input	Operation
DIR	
L	B TO A
H	A TO B

11 Application Note

The GT74LVC2T45 device can be used in level-translation applications for interfacing devices or systems operating at different interface voltages with one another. The maximum output current can be up to 32 mA when device is powered by 5 V.

11.1 Typical Application

Fig.11-1 shows the GT74LVC2T45 being used in a bidirectional logic level-shifting application. Because the GT74LVC2T45 does not have an output-enable (OE) pin, the system designer should take precautions to avoid bus contention between SYSTEM-1 and SYSTEM-2 when changing directions.

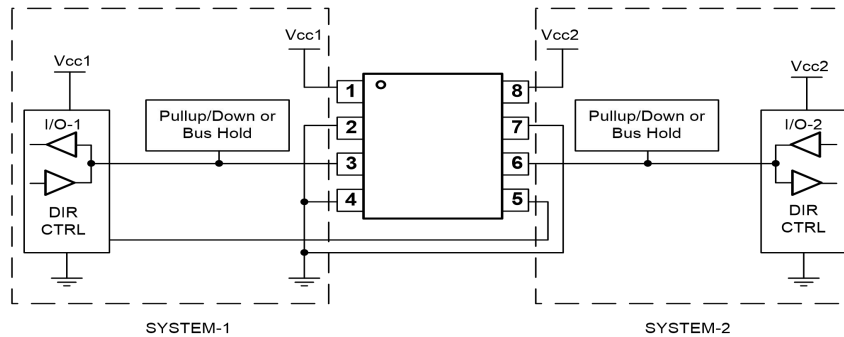

Fig.11-1. Typical Application Circuit

11.2 Enable Times

$$TPZH \text{ (DIR to A)} = TPLZ \text{ (DIR to B)} + TPLH \text{ (B to A)}$$

$$TPZL \text{ (DIR to A)} = TPHZ \text{ (DIR to B)} + TPHL \text{ (B to A)}$$

$$TPZH \text{ (DIR to B)} = TPLZ \text{ (DIR to A)} + TPLH \text{ (A to B)}$$

$$TPZL \text{ (DIR to B)} = TPHZ \text{ (DIR to A)} + TPHL \text{ (A to B)}$$

In a bidirectional application, these enable times provide the maximum delay from the time the DIR bit is switched until an output is expected. For example, if the GT74LVC2T45 initially is transmitting from A to B, then the DIR bit is switched; the B port of the device must be disabled before presenting it with an input. After the B port has been disabled, an input signal applied to it appears on the corresponding A port after the specified propagation delay.

12 Package Outline Dimension

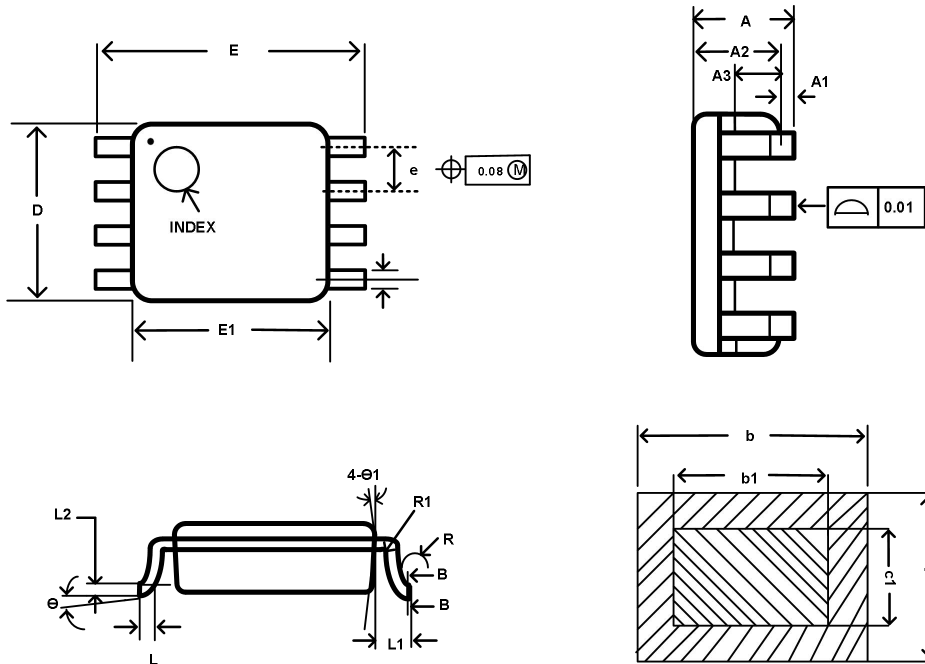
VSSOP8

Symbol	Dimensions in Millimeters			Dimensions in Inches		
	Min	Nom	Max	Min	Nom	Max
A	-	-	0.90	-	-	0.035
A1	0	0.05	0.10	0.000	0.002	0.004
A2	0.65	0.75	0.80	0.026	0.030	0.031
A3	0.32	0.37	0.42	0.013	0.015	0.017
b	0.17	-	0.27	0.007	-	0.011
b1	0.17	0.20	0.23	0.007	0.008	0.009
c	0.10	-	0.18	0.004	-	0.007
c1	0.10	0.13	0.14	0.004	0.005	0.006
D	1.90	2.00	2.10	0.075	0.079	0.083
E	3.00	3.10	3.20	0.118	0.122	0.126
E1	2.20	2.30	2.40	0.087	0.091	0.094
e	0.40	0.50	0.60	0.016	0.020	0.024
L	0.20	0.26	0.35	0.008	0.010	0.014
L1	0.40REF			0.016REF		
L2	0.12BSC			0.005BSC		
R	0.07	-	-	0.003	-	-
R1	0.07	-	-	0.003	-	-
θ	0°	-	6°	0°	-	6°
θ1	9°	12°	15°	9°	12°	15°

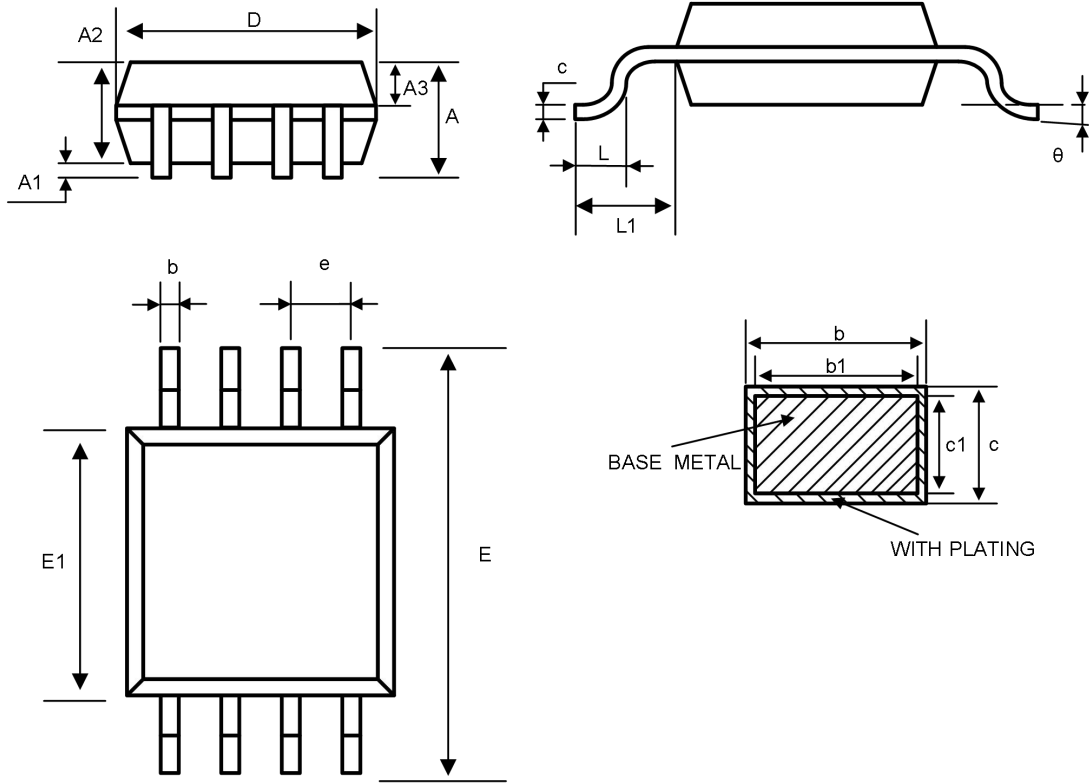
12 Package Outline Dimension(Continued)
MSOP8

Symbol	Dimensions in Millimeters			Dimensions in Inches		
	Min.	Nom.	Max.	Min.	Nom.	Max.
A	—	—	1.10	—	—	0.043
A1	0.05	—	0.15	0.002	—	0.006
A2	0.75	0.85	0.95	0.030	0.033	0.037
A3	0.30	0.35	0.40	0.012	0.014	0.016
b	0.28	—	0.36	0.011	—	0.014
b1	0.27	0.30	0.33	0.011	0.012	0.013
c	0.15	—	0.19	0.006	—	0.007
c1	0.14	0.15	0.16	0.006	0.006	0.006
D	2.90	3.00	3.10	0.114	0.118	0.122
E	4.70	4.90	5.10	0.185	0.193	0.201
E1	2.90	3.00	3.10	0.114	0.118	0.122
e	0.65BSC			0.026BSC		
L	0.40	—	0.70	0.016	—	0.028
L1	0.95REF			0.037REF		
θ	0	—	8°	0	—	8°

13 Tape and Reel Information

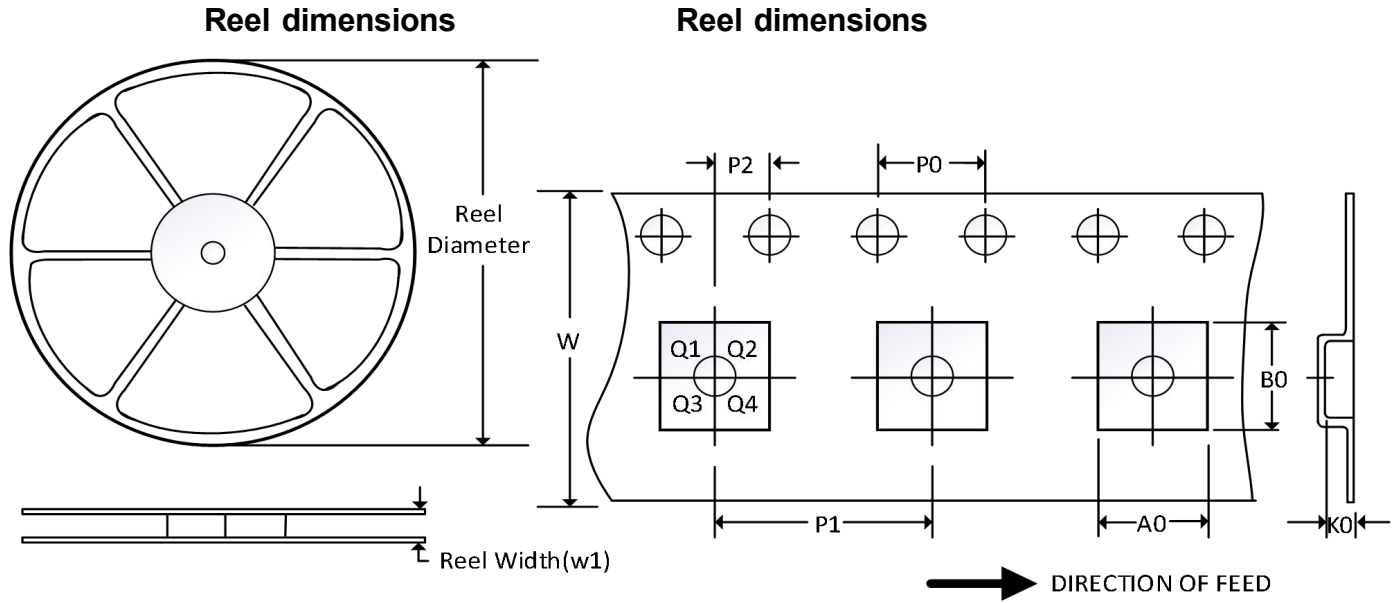

Note: The picture is only for reference. Please make the object as the standard.

Key Parameter List of Tape and Reel

Package Type	Reel Diameter	Reel Width (mm)	A0 (mm)	B0 (mm)	K0 (mm)	P0 (mm)	P1 (mm)	P2 (mm)	W (mm)	Pin1 Quadrant
VSSOP8	7"	9.5	2.25	3.35	1.4	4	4	2	8	Q3
MSOP8	13"	12.4	5.20	3.30	1.50	4.0	8.0	2.0	12.0	Q1

Note:

(1)All dimensions are nominal.

(2)Plastic or metal protrusions of 0.15mm maximum per side are not included.