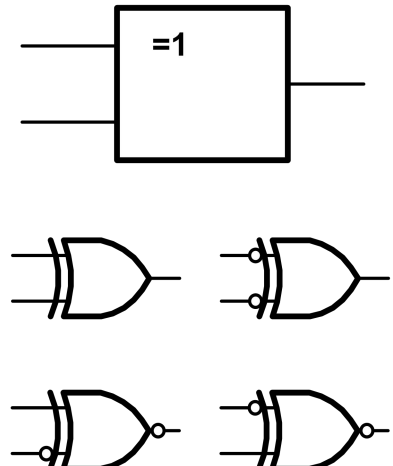

GT74LVC1G86

Single 2-Input Exclusive-OR Gate

1 Features	2 Application
<ul style="list-style-type: none"> - Operate from 1.65 V to 5.5 V - Specified from -40°C to 125°C - Inputs accept voltages to 5.5V - Max t_{pd} of 6ns at 3.3V - Low power consumption, 10μA max I_{CC} - ± 24-mA output drive at 3.3V - I_{off} supports partial-power-down mode 	<ul style="list-style-type: none"> - Wireless headsets - Motor drives and controls - TVs - Set-top boxes - Audio

3 Description	Circuit Diagram
<p>This single 2-input exclusive-OR gate is designed for 1.65V to 5.5V V_{CC} operation.</p> <p>The GT74LVC1G86 performs the Boolean function $Y=A \oplus B$ or $Y=\bar{A}B+AB\bar{}$ in positive logic.</p> <p>A common application is as a true/complement element. If the input is low, the other input is reproduced in true form at the output. If the input is high, the signal on the other input is reproduced inverted at the output.</p> <p>This device is fully specified for partial-power-down applications using I_{off}. The I_{off} circuitry disables the outputs, preventing damaging current backflow through the device when it is powered down.</p>	

4 Revision History

Revision	Date	Note
Rev. A0. 0	2023. 09. 02	Original Version
Rev. A0. 1	2023. 12. 26	1.Updated Package Qty 2.Added Tape and Reel Information 3.Added Marking 4.Added MSL
Rev. A1. 0	2024. 04. 10	1.Updated Electrical Specifications 2.Added Typical Characteristics

The latest datasheet version should be checked on the GTIC official website, as the company does not actively inform customers about updates to the datasheet.

5 Device Summary, Pin and Packages

Table. 5-1. Device Summary⁽¹⁾

Serial Name	Part Name	Package	Body Size (Nom)	Marking ⁽²⁾	MSL ⁽³⁾	Package Qty
GT74LVC1G86	GT74LVC1G86S5	SOT23-5	2.90mm×1.60mm×1.10mm	1G86 XXXXX	3	Tape and Reel,3000
	GT74LVC1G86C5	SC70-5	2.10mm×1.25mm×1.00mm	1G86 XXXXX	3	Tape and Reel,3000

(1) For all available packages, please contact product sales.

(2) There may be additional marking, which relates to the lot trace code information (data code and vendor code), the logo or the environmental category on the device.

(3) MSL, The Moisture Sensitivity Level rating according to the JEDEC industry standard classifications.

(4) "XXXXX" in Marking will be appeared as the batch code.

5 Device Summary, Pin and Packages(Continued)

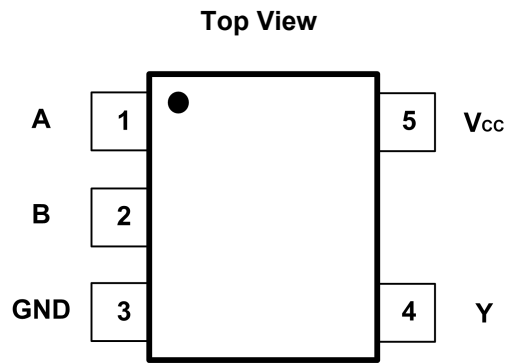

**Fig. 5-1. GT74LVC1G86: S5 (SOT23-5) Package
GT74LVC1G86: C5 (SC70-5) Package**

Table. 5-2. Pin Definition

Pin		I/O	Description
Name	S5 C5		
A	1	I	Input A
B	2	I	Input B
Y	4	O	Output Y
V _{CC}	5	-	Positive Supply
GND	3	-	Ground

6 Voltage, Temperature, ESD and Thermal Ratings

6.1 Absolute Maximum Ratings

Parameters		Min.	Max.	Unit
V _{CC}	Supply voltage range	-0.5	6.5	V
V _I	Input voltage range	-0.5	6.5	V
V _O	Voltage range applied to any output in the high-impedance or power-off state	-0.5	6.5	V
V _O	Voltage range applied to any output in the high or low state	-0.5	V _{CC} +0.5	V
I _{IK}	Input clamp current	V _I <0	-50	mA
I _{OK}	Output clamp current	V _O <0	-50	mA
I _O	Continuous output current		±50	mA
	Continuous current through V _{CC} or GND		±100	mA
T _{stg}	Storage temperature range	-55	150	°C
T _{stg}	Storage temperature	-55	150	°C

(1) Stresses beyond those listed under "Absolute Maximum Ratings" may cause permanent damage to the device. These are stress ratings only, and functional operation of the device at these or any other conditions beyond those indicated under "Recommended Operating Conditions" is not implied. Exposure to absolute-maximum-rated conditions for extended periods may affect device reliability.

(2) The input and output negative-voltage ratings may be exceeded if the input and output current ratings are observed.

(3) The output positive-voltage rating may be exceeded up to 6.5 V maximum if the output current rating is observed.

6.2 ESD Ratings

ESD		Value	Unit
V(ESD)	Electrostatic discharge	Human-Body Model (HBM)	8 K
		Charged-Device Model (CDM)	1.25 K

(1) JEDEC document JEP155 states that 500-V HBM allows safe manufacturing with a standard ESD control process.

(2) JEDEC document JEP157 states that 250-V CDM allows safe manufacturing with a standard ESD control process.

6 Voltage, Temperature, ESD and Thermal Ratings(Continued)

6.3 Recommended Operating Conditions⁽¹⁾

Over operating free-air temperature range (unless otherwise noted)

Symbol	Parameters		Min.	Max.	Unit
V _{CC}	Supply Voltage		1.65	5.5	V
V _{IH}	High-Level Input Voltage	V _{CC} =1.65V to 1.95V	0.65×V _{CC}		V
		V _{CC} =2.3V to 2.7V	1.7		
		V _{CC} =3V to 3.6V	2		
		V _{CC} =4.5V to 5.5V	0.7×V _{CC}		
V _{IL}	Low-Level Input Voltage	V _{CC} =1.65V to 1.95V		0.35×V _{CC}	V
		V _{CC} =2.3V to 2.7V		0.7	
		V _{CC} =3V to 3.6V		0.8	
		V _{CC} =4.5V to 5.5V		0.3×V _{CC}	
V _I	Input Voltage		0	5.5	V
V _O	Output Voltage		0	V _{CC}	V
I _{OH}	High-Level Output Current	V _{CC} =1.65V		-4	mA
		V _{CC} =2.3V		-8	
		V _{CC} =3V		-16	
				-24	
		V _{CC} =4.5V		-32	
I _{OL}	Low-Level Output Current	V _{CC} =1.65V		4	mA
		V _{CC} =2.3V		8	
		V _{CC} =3V		16	
				24	
		V _{CC} =4.5V		32	
Δt/Δv	Input Transition Rise or Fall Rate	V _{CC} =1.8V±0.15V, 2.5V±0.2V		20	ns/V
		V _{CC} =3.3V±0.3V		10	
		V _{CC} =5V±0.5V		5	
TA	Operating Free-air Temperature	All Other Packages	40	125	°C

(1) All unused digital inputs of the device must be held at V_{CC} or GND to ensure proper device operation.

6.4 Thermal Information

Package Type	θ _{JA}	θ _{JC}	Unit
SC70-5	400	150	°C/W
SOT23-5	250	81	°C/W

7 Electrical Specifications

7.1 Electrical Characteristics

FULL=−40°C to +125°C, Typical values are at TA=+25°C. (unless otherwise noted)

Parameters	Symbol	Conditions	V _{CC}	T _A	Min.	Typ.	Max.	Unit
Output								
High-Level Output Voltage	V _{OH}	I _{OH} =−100μA	1.65V to 5.5V	FULL	V _{CC} −0.1			V
		I _{OH} =−4mA	1.65		1.2			
		I _{OH} =−8mA	2.3		1.9			
		I _{OH} =−16mA	3		2.4			
		I _{OH} =−24mA			2.3			
		I _{OH} =−32mA	4.5		3.8			
Low-Level Output Voltage	V _{OL}	I _{OL} =100μA	1.65V to 5.5V	FULL			0.1	V
		I _{OL} =4mA	1.65				0.45	
		I _{OL} =8mA	2.3				0.3	
		I _{OL} =16mA	3				0.4	
		I _{OL} =24mA					0.55	
		I _{OL} =32mA	4.5				0.55	
Off-State Current	I _{off}	V _I or V _O =5.5V	0V	FULL			±10	μA
Input								
Input Leakage Current	I _I	A or B input, V _I =5.5V or GND	0V to 5.5V	FULL			±5	μA
Input Capacitance	C _i	V _I =V _{CC} or GND	3.3V	FULL		6		pF
Power Supply								
Power Supply Range	V _{CC}		1.65V to 5.5V	FULL	1.65		5.5	V
Supply Current	I _{CC}	V _I =5.5 V or GND, I _O =0	1.65V to 5.5V	FULL			10	μA
Delta Power Current	ΔI _{CC}	One Input at V _{CC} − 0.6 V, Other Inputs at V _{CC} or GND	3V to 5.5V	FULL			500	μA

(1) All unused digital inputs of the device must be held at V_{CC} or GND to ensure proper device operation.

7.2 Switching Characteristics

Over recommended operating free-air temperature range, C_L=30pF or 50 pF (unless otherwise noted)

Parameter	From(Input)	To(Output)	−40°C to +125°C								Units
			V _{CC} =1.8V±0.15V		V _{CC} =2.5V±0.2V		V _{CC} =3.3V±0.3V		V _{CC} =5V±0.5V		
			Min	Max	Min	Max	Min	Max	Min	Max	
t _{pd}	A or B	Y	3.5	12	1.8	7	1.3	6	1	5	ns

7.3 Operating Characteristics

TA=−40°C to +125°C

Parameter		Test Conditions	V _{CC} =1.8V	V _{CC} =2.5V	V _{CC} =3.3V	Units
			Typ	Typ	Typ	
C _{pd}	Power Dissipation Capacitance	f=10Mhz	20	20	20	pF

8 Typical Characteristics

Typical values are at TA=+25°C (unless otherwise noted)

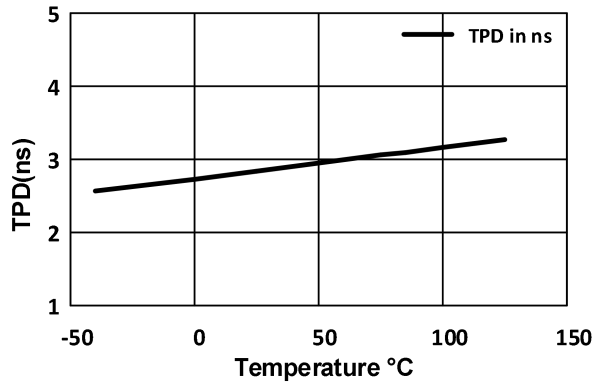

Fig.8-1. TPD Across Temperature at 3.6V V_{CC}

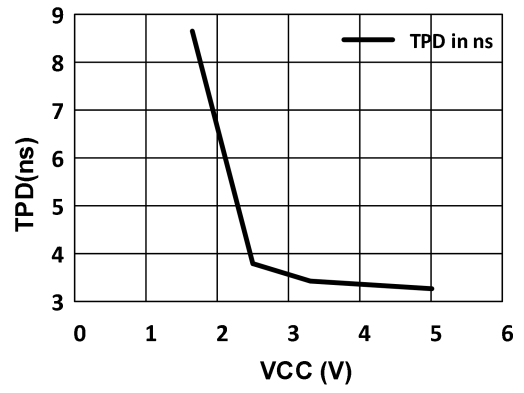
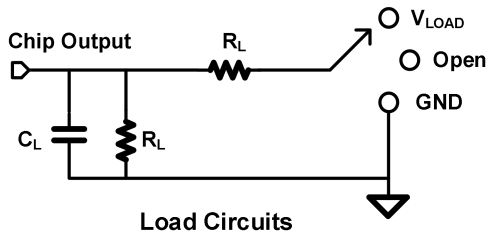

Fig.8-2. TPD Across V_{CC} at 25°C

9 Measurement Information



TEST	S1
T_{PHL}/T_{PLH}	OPEN
T_{PLZ}/T_{PZL}	V_{LOAD}
T_{PHZ}/T_{PZH}	GND

V_{CC}	Inputs		V_M	V_{LOAD}	C_L	R_L	V_{Δ}
	V_i	T_r/T_f					
$1.8V \pm 0.15V$	V_{CC}	$\leq 2ns$	$V_{CC}/2$	$2 \times V_{CC}$	15pF	1M Ω	0.15V
$2.5V \pm 0.15V$	V_{CC}	$\leq 2ns$	$V_{CC}/2$	$2 \times V_{CC}$	15pF	1M Ω	0.15V
$3.3V \pm 0.15V$	3V	$\leq 2.5ns$	1.5V	6V	15pF	1M Ω	0.3V
$5V \pm 0.15V$	V_{CC}	$\leq 2.5ns$	$V_{CC}/2$	$2 \times V_{CC}$	15pF	1N Ω	0.3V

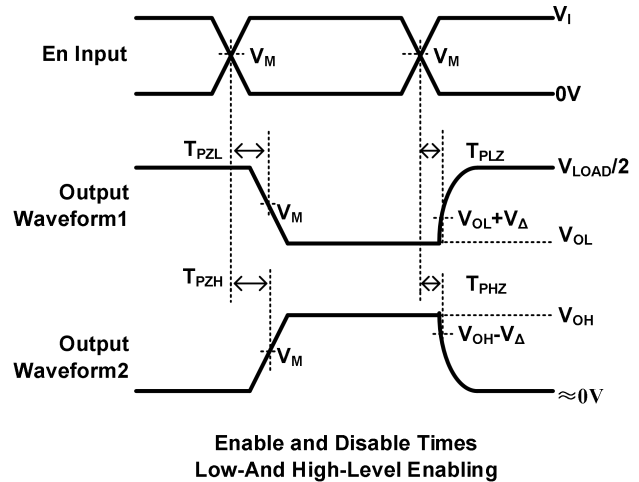
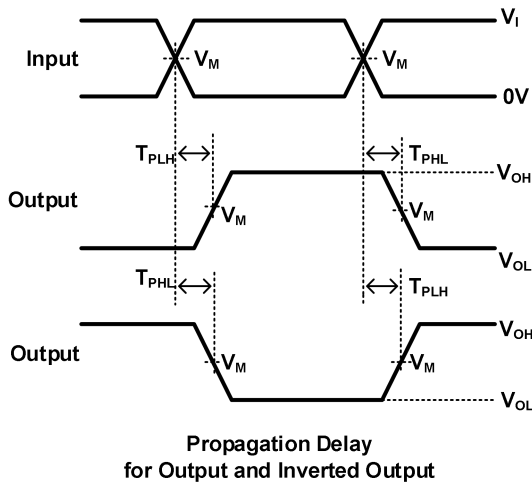
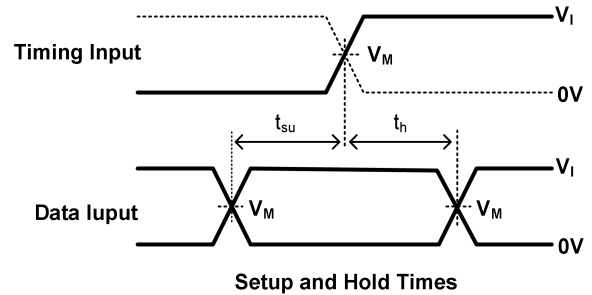
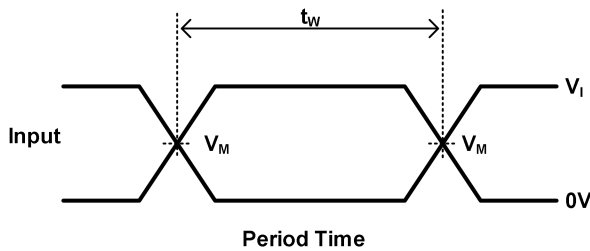

Notes: A. C_L includes probe and jig capacitance.

B. Waveform 1 is for an output with internal conditions such that the output is low, except when disabled by the output control. Waveform 2 is for an output with internal conditions such that the output is high, except when disabled by the output control.

C. All input pulses are supplied by generators having the following characteristics: PRR 10 MHz, Z = 50 .

D. The outputs are measured one at a time, with one transition per measurement.

E. t_{PLZ} and t_{PHZ} are the same as t_{dis} .

F. t_{PZL} and t_{PZH} are the same as t_{en} .

G. t_{PLH} and t_{PHL} are the same as t_{pd} .

H. All parameters and waveforms are not applicable to all devices.

10 Detailed Description

10.1 Overview

The GT74LVC1G86 device performs the Boolean function $Y = \bar{A}B + A\bar{B}$ in positive logic. This single 2-input exclusive-OR gate is designed for 1.65V to 5.5V V_{CC} operation.

A common application is as a true and complement element. If the input is low, the other input is reproduced in true form at the output. If the input is high, the signal on the other input is reproduced inverted at the output.

This device is fully specified for partial-power-down applications using I_{off} . The I_{off} circuitry disables the outputs, preventing damaging current backflow through the device when it is powered down.

10.2 Device Functional Modes

Table.10-1. Function Table

Inputs		Output
A	B	Y
L	L	L
L	H	H
H	L	H
H	H	L

11 Application Note

The GT74LVC1G86 device can accept input voltages up to 5.5 V at any valid V_{CC} which makes the device suitable for down translation. This feature of the GT74LVC1G86 makes it ideal for various bus interface applications.

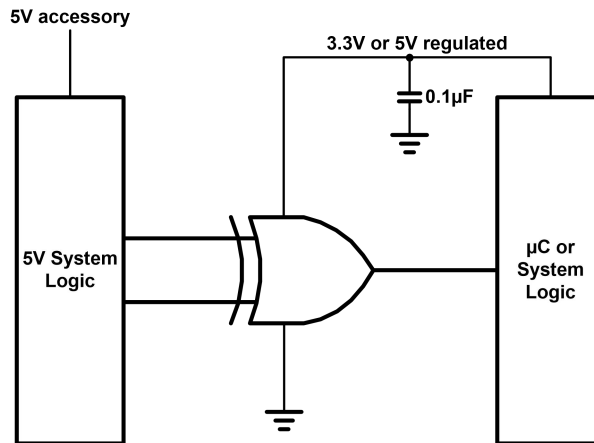
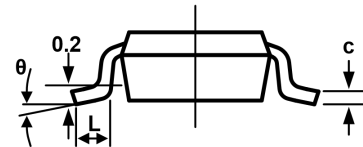
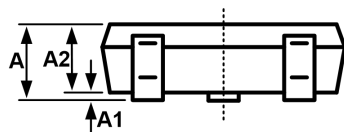
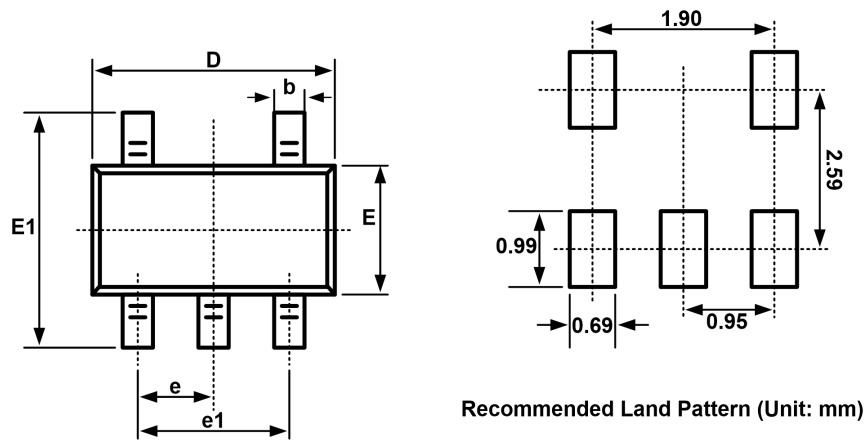

Fig.11-1. Typical Application Schematic

This device uses CMOS technology and has balanced output drive. Take care to avoid bus contention because it can drive currents that would exceed maximum limits. The high drive will also create fast edges into light loads, so routing and load conditions should be considered to prevent ringing.

12 Package Outline Dimension

SOT23-5



Symbol	Dimensions In Millimeters		Dimensions In Inches	
	Min	Max	Min	Max
A	1.050	1.250	0.041	0.049
A1	0.000	0.100	0.000	0.004
A2	1.050	1.150	0.041	0.045
b	0.300	0.500	0.012	0.020
c	0.100	0.200	0.004	0.008
D	2.820	3.020	0.111	0.119
E	1.500	1.700	0.059	0.067
E1	2.650	2.950	0.104	0.116
e	0.950(BSC)		0.037(BSC)	
e1	1.800	2.000	0.071	0.079
L	0.300	0.600	0.012	0.024
L1	0.600REF		0.024REF	
θ	0°	8°	0°	8°

12 Package Outline Dimension(Continued)

SC70-5

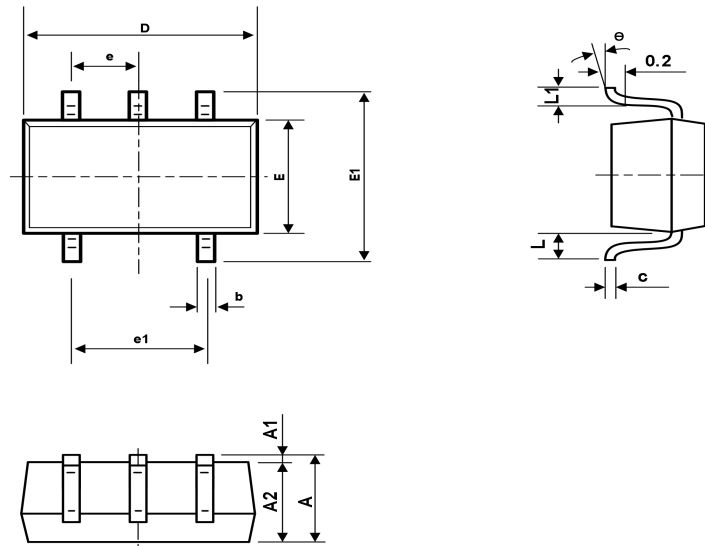

symbol	Dimension In Millimeters		Dimensions In Inches	
	Min	Max	Min	Max
A	0.900	1.100	0.035	0.043
A1	0.000	0.100	0.000	0.004
A2	0.900	1.000	0.035	0.039
b	0.150	0.350	0.006	0.014
c	0.110	0.175	0.004	0.007
D	2.000	2.200	0.079	0.087
E	1.150	1.350	0.045	0.053
E1	2.150	2.450	0.085	0.096
e	0.650TYP		0.026TYP	
e1	1.200	1.400	0.047	0.055
L	0.525REF		0.021REF	
L1	0.260	0.460	0.010	0.018
e	0°	8°	0°	8°

13 Tape and Reel Information

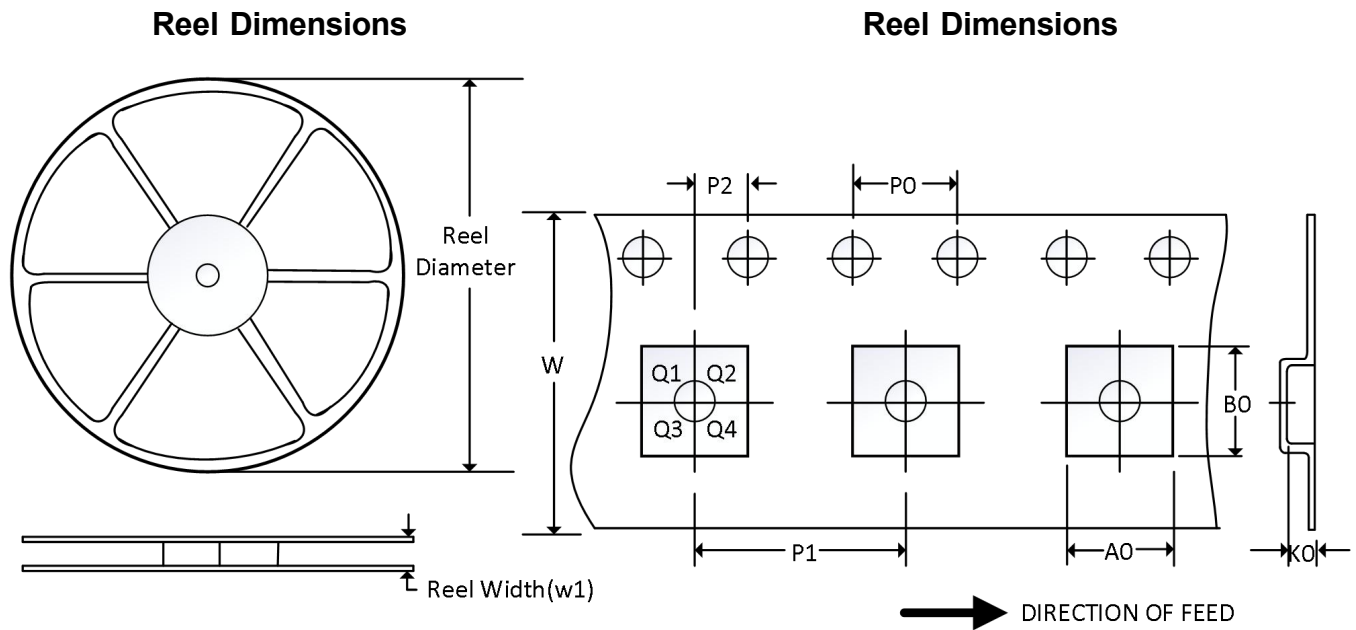

NOTE: The picture is only for reference. Please make the object as the standard.

Key Parameter List of Tape and Reel

Package Type	Reel Diameter	Reel Width(mm)	A0 (mm)	B0 (mm)	K0 (mm)	P0 (mm)	P1 (mm)	P2 (mm)	W (mm)	Pin1 Quadrant
SOT23-5	7"	9.5	3.20	3.20	1.40	4.0	4.0	2.0	8.0	Q3
SC70-5	7"	9.5	2.25	2.55	1.20	4.0	4.0	2.0	8.0	Q3

NOTE:

1. All dimensions are nominal.
2. Plastic or metal protrusions of 0.15mm maximum per side are not included.